



**PDHonline Course C497 (4 PDH)**

---

# **FHWA Bridge Maintenance Manual—Substructure**

*Instructor: Mark P. Rossow, Ph.D, PE Retired*

**2020**

**PDH Online | PDH Center**

5272 Meadow Estates Drive  
Fairfax, VA 22030-6658  
Phone: 703-988-0088  
[www.PDHonline.com](http://www.PDHonline.com)

An Approved Continuing Education Provider

## **XII. SUBSTRUCTURE MAINTENANCE PROCEDURES**

### **A. MAINTENANCE OF BRIDGE SEATS AND CAPS**

#### **INTRODUCTION**

Substructure caps of both abutments and piers provide the seats or bases upon which bearing systems that directly support superstructures rest. Many bridges have open joints located over the abutments and piers. Some bridges have drainage troughs located below the open joints to intercept the runoff and debris that falls through the deck expansion joints. These troughs discharge the debris beyond the substructure units into the stream or onto the ground below.

In the case of a bridge without drainage troughs, the debris and runoff, which may contain deicing chemicals, are accumulated on top of the substructure caps and can create a serious problem if not removed. Many bridges, even with drainage troughs, experience the same problem due to clogging and run-over, so that all bridges should be included in a regular substructure cap-cleaning program.

#### **PROBLEMS ASSOCIATED WITH SUBSTRUCTURE CAPS**

The presence on the caps of debris, which tends to hold water and deicing chemicals for extended periods, results in corrosion of bearing systems. The penetration of the deicing chemicals into the concrete can result in corrosion of the reinforcing steel, which in turn expands and breaks out (spalls) the covering concrete.

When the bearing system is frozen by the corrosion, additional stress is introduced into the substructure cap that can cause spalling or damage to the bearing system. In addition, if the superstructure or deck joints are not kept clear of debris, the joint may not close as the deck expands and the deck can be prevented from expanding as it was designed to do. If there is no other expansion joint that can compensate for the jammed joint the expansion force will be transmitted to the bearing system. Overloading of the bearing system can result in fracture of the substructure cap and loss of bearing for the beam ends (See Exhibit XII.1).

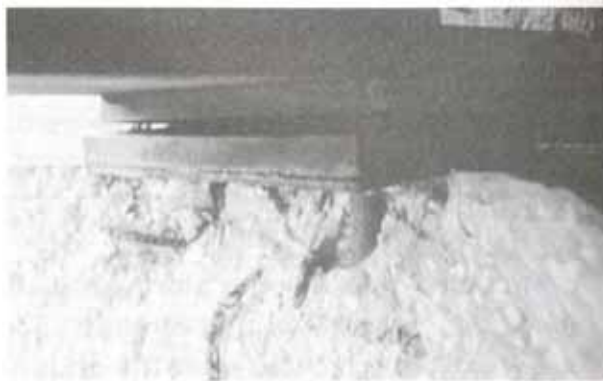

**Exhibit XII.1 Fracture of Bearing Seat**

## MAINTENANCE

A routine cap-cleaning program is recommended. The use of a high-pressure pump with adequate length of hose to flush out the substructure cap from every angle is an effective cleaning method. The superstructure expansion joint troughs and drainage system or downspouts should be cleaned at the same time. This procedure should be scheduled in the spring as soon as the winter deicing program is over in cold climates, and at regular intervals in warm climates depending upon local conditions. Flushing the bridge deck should be included. The flushing process proceeds from the top down, If the water supply is limited, the substructure caps should be cleaned first and then the downspouts flushed. Rain will flush the deck and be carried away by the drains, but it is of no help in cleaning substructure caps (See Exhibit XII.2).



**Exhibit XII.2 Washing Bearing Seat**

## PREVENTIVE MAINTENANCE

The following preventive maintenance measures are effective:

- Installation of deck expansion joint drain troughs, if they can be accommodated, to protect the caps is a good preventive maintenance practice on bridges that do not already have them.
- Surface protection for the concrete of the substructure caps should be applied using one or both of the two types of protection described in the following paragraphs.
  - **Sealants** that impregnate the concrete, reduce its surface porosity and stabilize the outer layer include Silane, Siloxane, and High Molecular Weight Methacrylate (HMWM).
  - **Coatings** that adhere to the concrete, seal the surface, bridge small cracks and provide some resistance to attacks by deicing chemicals include: Epoxy Resins, Hard Urethane, and Methacrylate.
  - Membranes that bridge cracks and provide maximum protection from deicing chemicals include Elastomeric Urethane, Vinyl, and Polyester.

Some states apply the protective coating to the bearing systems as well as to the substructure caps. Obviously this can only be effective if the protective coating is compatible with the paint system used on the bearings. When coating concrete caps, the best procedure is to extend the protective film on the abutments to a minimum of one foot below the bridge seat. On piers the extent of the coating may depend, to some extent, on appearance.

## **REPAIR PROCESS**

Problems often found in concrete bridge seats include the deterioration of concrete and the corrosion of reinforcing bars. Such problems are caused by moisture and contaminants falling through leaking deck joints. A horizontal crack along the face of the pier cap, 75 to 100 mm (3 to 4 inches) from the top, normally indicates that the top mat of rebars has expanded because of corrosion and has forced up (delaminated) the concrete.

When a superstructure moves beyond the space that is provided for it in the bearing assemblies, pressure is created on the anchor bolts. This can be caused by an inadequate design, improper placement of the assemblies, movement of the superstructure, or corrosion related friction between the sliding surfaces. Lateral force such as large debris striking a bridge during periods of high water or an over-height vehicle hitting a beam can also create large forces on the anchor bolts. The pressure from the anchor bolts is then transmitted to the substructure cap, which can cause damage to the bridge seats or cracks in other parts of the substructure such as the columns.

No bearing device was provided on some older concrete bridges except for a thin fabric or paper bond breaker. Friction created by the beam or bearing device sliding directly on the bridge seat can cause the edge of the seat to shear. Insufficient reinforcement can contribute to this problem.

### **Preliminary Planning**

During the preliminary planning stage, necessary substructure repair procedures should be determined. These procedures should then be scheduled in a logical order, and they may include the following:

- Identify damage by sounding and marking the unsound concrete.
- Make provisions to correct the cause of damage.

### **Jacking Procedures**

If the deterioration is caused by loads, or in case of extensive concrete deterioration, the superstructure may be lifted (to take the load off the substructure) prior to repair. Also, repair may require raising the superstructure in order to provide workspace. The procedures for jacking are as follows:

- Plan to remove traffic from the bridge during jacking.
- Determine the size, number, and location of jacks that are required.
- Ensure that jacking will not damage joints, bearing assemblies, or area supporting jacks.

## Resource Requirements

The resources that will be needed should be determined. They may include:

- Jacking equipment
- Form carpentry
- Concrete sawing and chipping equipment
- Necessary staging

## Repair Procedures

The substructure cap can be repaired or a new cap cast to offset any settlement that might have occurred to the substructure (See Exhibit XII.3). The repair procedure follows:

1. Construct a temporary bent for supporting jacks and blocking if jacking from abutment or pier elements cannot be accomplished.
2. Remove traffic from the bridge while jacking the superstructure.
3. Lift jacks in unison to prevent a concentration of stress in one area and possible damage to the superstructure.
4. If the bridge will carry traffic during repairs, restrict vehicles away from repair area as much as possible.
5. Saw cut around concrete to be removed and avoid cutting reinforcing steel.
6. Remove deteriorated concrete to horizontal and vertical planes using pneumatic breakers.
7. Add new reinforcing steel where required.
8. Apply bonding material to prepared surface that will interface with new concrete. Bonding material shall not dry out prior to casting the new concrete; otherwise, do not apply a bonding material.
9. Form as required and cast new concrete.
10. Service, repair, or replace bearings as necessary.
11. After concrete has reached required strength, remove forming, blocking, jacks and temporary supports.

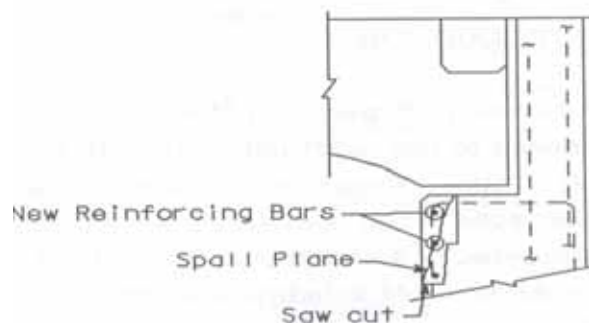

**Exhibit XII.3 Reconstruction of Abutment Seat**

---

## **B. REPAIR OF SUBSTRUCTURE, GENERAL**

---

### **INTRODUCTION**

A review of Chapter VII "Materials" is suggested to prepare for this session. Repairs to the substructure in general tend to be performed using basic materials and techniques. Repairs performed underwater however, require special techniques that will be discussed at the end of this chapter. Specific repairs involving piles and pile bents will be presented later in this chapter. Repairs that involve undermining of substructure units caused by scour are included in Chapter XIII.

Substructure problems include deterioration (particularly at the water line), cracking (usually related to settlement), impact damage (associated with traffic under the bridge), and shear damage (associated with movement or approach pavement pressure). Since most substructure units are concrete, repairs are often concrete related. If the concrete substructure is exposed to salt water, either from the deck or from below, there are likely to be the same rebar corrosion and spalling problems associated with the deck. In addition to the problems listed above, timber substructures are damaged by decay and vermin attack.

Substructure repairs are often very costly involving temporary bents to support the superstructure. Preventive maintenance (PM) is a cost-effective method of avoiding these repairs. PM includes removing debris and pressure-washing seats, caps and other surfaces exposed to salt.

### **PROTECTING THE SUBSTRUCTURE**

#### **DETERIORATION AT WATERLINE**

There are several deterioration mechanisms acting at the waterline. Wet/dry and freeze/thaw cycles accelerate deterioration. Material carried by the water cause an abrasive action that contributes to surface damage at the waterline. Protective coatings and fiberglass liners can be applied at the waterline to provide protection against deterioration at this location.

#### **SALT DAMAGE**

Protection against salt-water damage is the same as on the deck. Coatings are effective for steel or concrete if applied early and reapplied when needed. Dense concrete, such as that attained with a pozzolin additive, is also effective in resisting salt-water damage.

#### **SETTLEMENT**

Where serious settlement is expected (either due to live loads or seismic loads) a soils and/or structural engineer should be consulted prior to taking measures to prevent the damage to the abutment or pier. A footing that is resting upon piles may require additional piles to stabilize it. Additional width of a spread footing may have to be constructed in order to stabilize it. In both

cases, increasing the height of the footing and adding top mat reinforcing steel will increase the capacity. Incorporation of additional piles into a concrete footing requires sufficient headroom under the bridge for pile driving equipment. See Exhibit XII.4.

### Construction Procedures

1. Excavate around the footing.
2. Remove concrete to expose the edges of lower mat of reinforcing steel.
3. Clean the existing concrete and reinforcing steel.
4. Drive all additional new piles (not required for spread footing).
5. Form the new extended footing.
6. Lap the new reinforcement to the existing exposed bars. If lapping is not feasible, drill and grout the new reinforcement to the existing concrete.
7. Place new top mat bars and the reinforcing cage.
8. Place and cure the concrete in the extended footing.
9. Backfill over the footing.

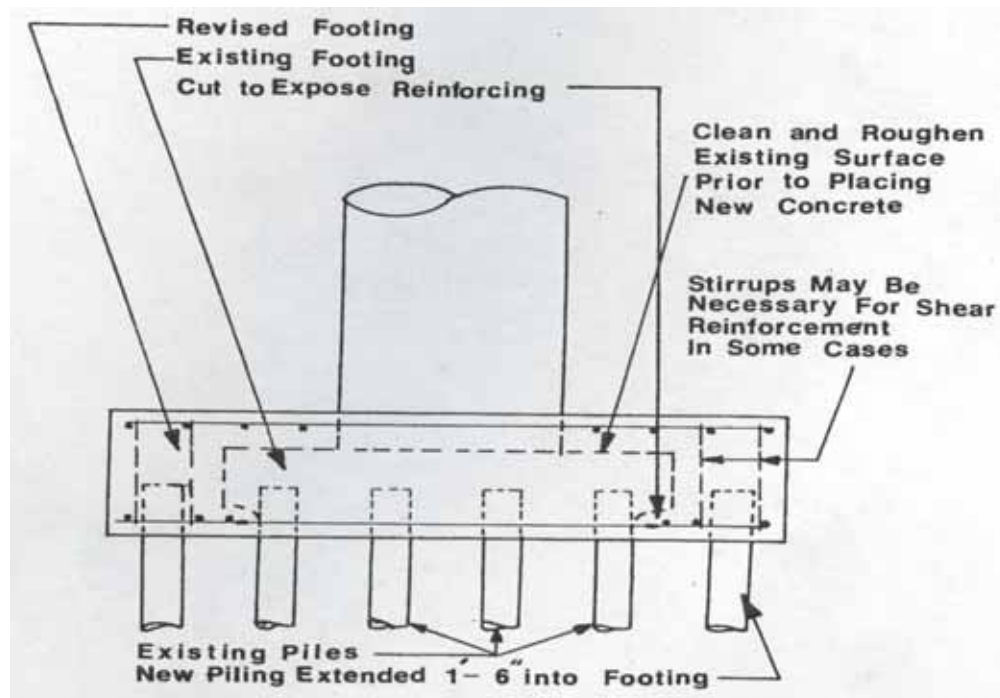

**Exhibit XII.4 Increasing Live Load Capacity of Existing Footing**

### IMPACT DAMAGE

Guardrails and energy dissipaters can be installed to help protect against damage from highway traffic under the bridge. On navigable waterways, where ships or barges may contact piers and abutments, adequate fenders are necessary to protect against mechanical damage. Steel plates can be installed on the upstream edge of an abutment or pier in order to reduce the damage caused by ice and debris. Plates should be of sufficient thickness and well fastened.

## **PRESSURE FROM APPROACH PAVEMENT**

Abutment damage caused by pressure from approach can be avoided by installing relief joints as described in Chapter XIII.

## **REPAIR OF BROKEN OR DETERIORATED WING WALLS**

Portions of an otherwise sound wingwall may be broken off by frost heave, ice that forms in voids created by fill settlement adjacent to the wall, ice in cracks, voids in the concrete, or insufficient air entrainment voids, which trap salts and thereby forestall deterioration. Deterioration may occur due to deicing, salt-rich snow and ice plowed onto the wing walls and retained by moisture-holding debris. Bad aggregates sometimes cause wingwall failure. The loss of portions of the wing wall can result in erosion of the fill and further damage to the wing wall and the approach.

The cause of the failure should be determined so that it may be corrected if possible and to ensure that any defects or deteriorated areas present can be removed in order to ensure an effective repair. The forming should be preplanned and the materials cut to size in advance if feasible. Any excavation required to gain sufficient working access and to facilitate the removal of defective concrete could be accomplished in advance of the repair.

## **MATERIALS REQUIRED**

The materials and equipment required to make this type of repair may vary but will usually include:

- Excavating equipment (backhoe)
- Air drill
- Tie screw or equivalent bolts
- Wood spacers, walers, etc.
- Reinforcing rods
- Granular back fill
- Hand tools
- Concrete removal equipment
- Anchor bolts and anchors
- Plywood sheet forming
- Cement concrete
- Epoxy-bonding agent
- Non-shrink grout
- Miscellaneous hardware

## **REPAIR PROCEDURE**

The repair, which is shown in Exhibit XII.5, consists basically of recasting the broken or deteriorated section as follows:

1. Excavate as required to set the dowels for formwork support.
2. Remove all fractured or deteriorated concrete to sound concrete by chipping, and blast clean to remove material left after chipping.
3. Drill and set dowels. Dowels, 13-mm diameter (#4) bars, are placed a minimum of 225 mm (9 inches) into sound concrete and set with non-shrink grout, 150 mm (18 inches) on center.
4. Set the dowels for formwork support and install the forms.



5. Just prior to placing the concrete, apply an epoxy-bonding agent to all existing concrete that is to come into contact with new concrete.
6. Cure concrete for a minimum of 7 days before backfilling with granular material, or until concrete has developed sufficient strength to resist the imposed lateral pressures.

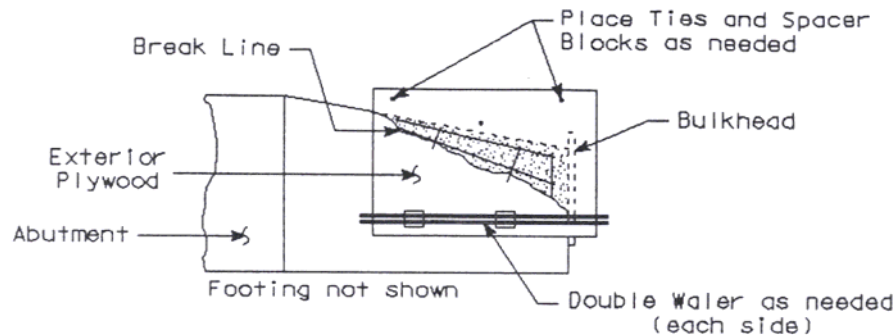

**Exhibit XII.5 Reconstruction of Wing Wall**

### **REPAIR OF ABUTMENT FACE**

The concrete in abutments may deteriorate from the effects of water, deicing chemicals, freeze cracking or impact by debris which results in breaking off the edges or portions of the face. This condition requires that repairs be made to prevent continued deterioration, particularly increased spalling due to moisture reaching the rebar and causing corrosion. This procedure is often used to face old rubble masonry or concrete made from large stone. It is helpful in correcting seat problems. See Exhibit XIV.6.

### **EQUIPMENT AND MATERIALS REQUIRED**

The equipment and materials needed for this rehabilitation are:

- Air compressor
- Tie screws and lag studs
- Forming material
- Cement concrete
- Gravel, stone, or riprap
- Concrete drilling equipment
- Wire reinforcing mesh
- Reinforcing steel
- Epoxy-bonding agent

### **REHABILITATION PROCEDURE**

The following steps in the rehabilitation procedure are normally required:

1. Establish traffic control, if necessary.
2. Remove deteriorated concrete by chipping and blast cleaning.
3. Drill and set the tie screws and a studs to support the formwork.
4. Set reinforcing steel and forms.
5. Apply epoxy-bonding agent to the concrete surface just before placing the concrete.
6. Place the cement concrete, cure, and remove the forms.
7. Install erosion control material.

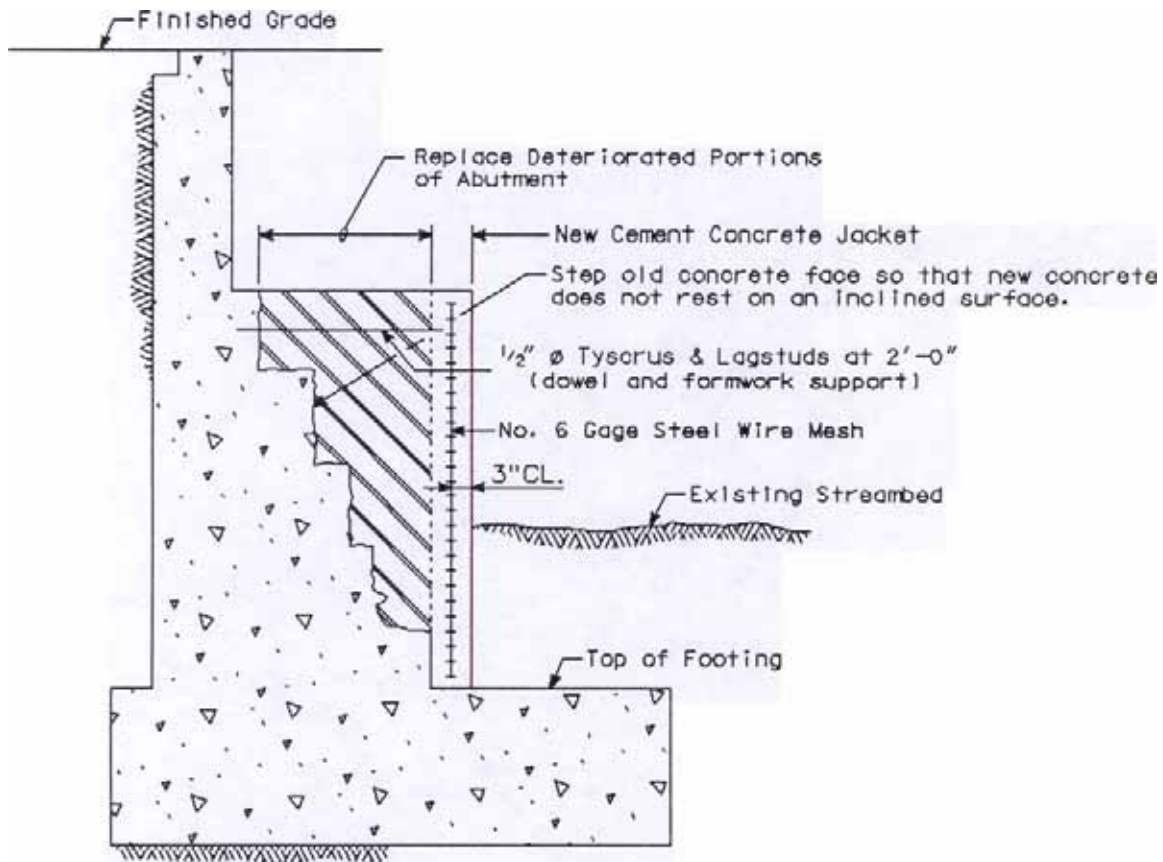

**Exhibit XI.6 Repair of Abutment Face**

## **REPAIR OF ABUTMENT BACKWALL**

Abutment backwalls can be damaged from several factors including shoving of the approach slab, wheel impact of vehicles from the joint, and salt contaminated run off from the joint. Damaged abutment backwalls may be partially or totally replaced as shown below and in Exhibit XII.7.

### **REPLACEMENT PROCEDURE**

- 1 If a steel armored joint is used, temporarily tack weld the abutment side of the steel armored joint to the deck side of the joint assembly. Certified personnel should perform welding.
- 2 Cut and excavate the approach slab or pavement to allow access to the backwall.
- 3 Remove deteriorated concrete from the backwall and clean concrete and reinforcing bars.
- 4 Place replacement bars by lapping them with the existing bars or by drilling and grouting.
- 5 Place forms for concrete.
- 6 Place and cure concrete. Insure concrete is placed beneath existing joints.
- 7 Remove forms and temporary tack welds on joints.
- 8 Backfill and compact subgrade under the approach slab or pavement.
- 9 Patch the approach slab or pavement.

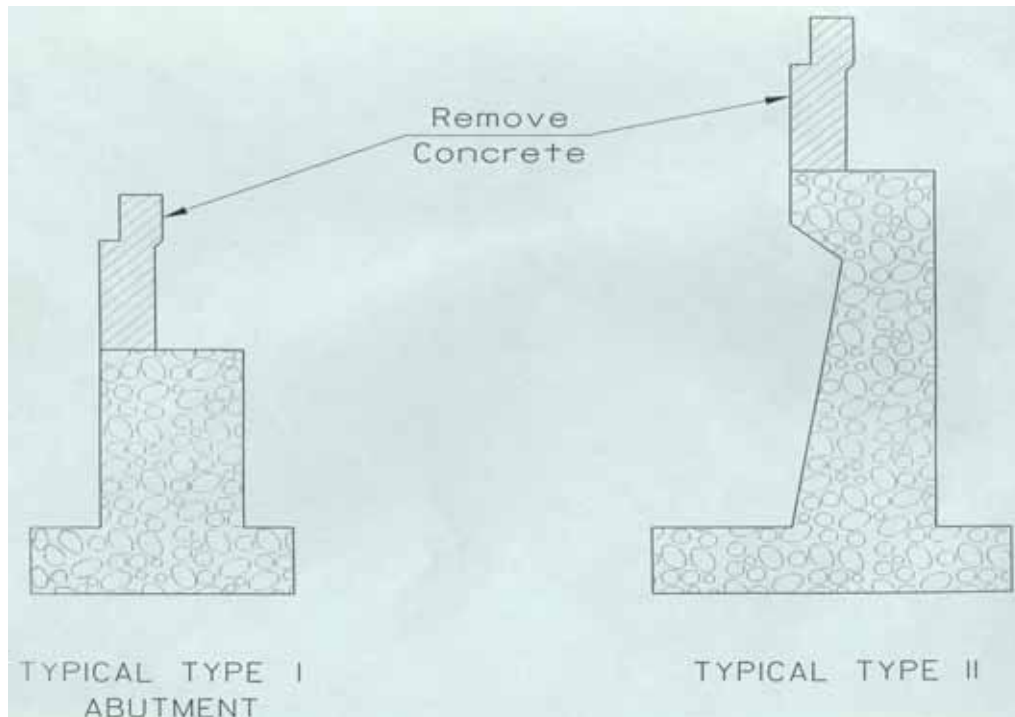

**Exhibit XII.7 Abutment Backwall Repair**

### **REPAIR OF CRACKED HAMMERHEAD PIER CAP**

Hammerhead concrete pier caps may develop cracking due to flexure and/or shear. External post-tensioning may be applied to repair these cracks. A competent engineer shall design this type of repair before the repair is initiated. The procedure as shown in Exhibit XII.8 includes the following steps:

#### **REPAIR PROCEDURE**

- 1 Epoxy inject all cracks in the pier cap and allow the epoxy to harden.
- 2 Obtain steel cables (or rods) for post-tensioning and PVC pipes as ducts for the bars for corrosion protection.
- 3 Erect all PVC pipe supports at both sides of the pier cap. Locate existing stirrups and horizontal bars in the cap prior to installing expansion bolts for the supports.
- 4 Erect PVC pipes (with post-tensioning steel inside) to the supports on the pier cap.
- 5 Erect post-tensioning anchorage assembly at both ends of the pier cap.
- 6 Post-tension the system to the required load per bar. Use a sequence to balance the loads during post-tensioning.
- 7 Grout the ducts and seal the post-tensioning anchorage against penetration of moisture and corrosion.

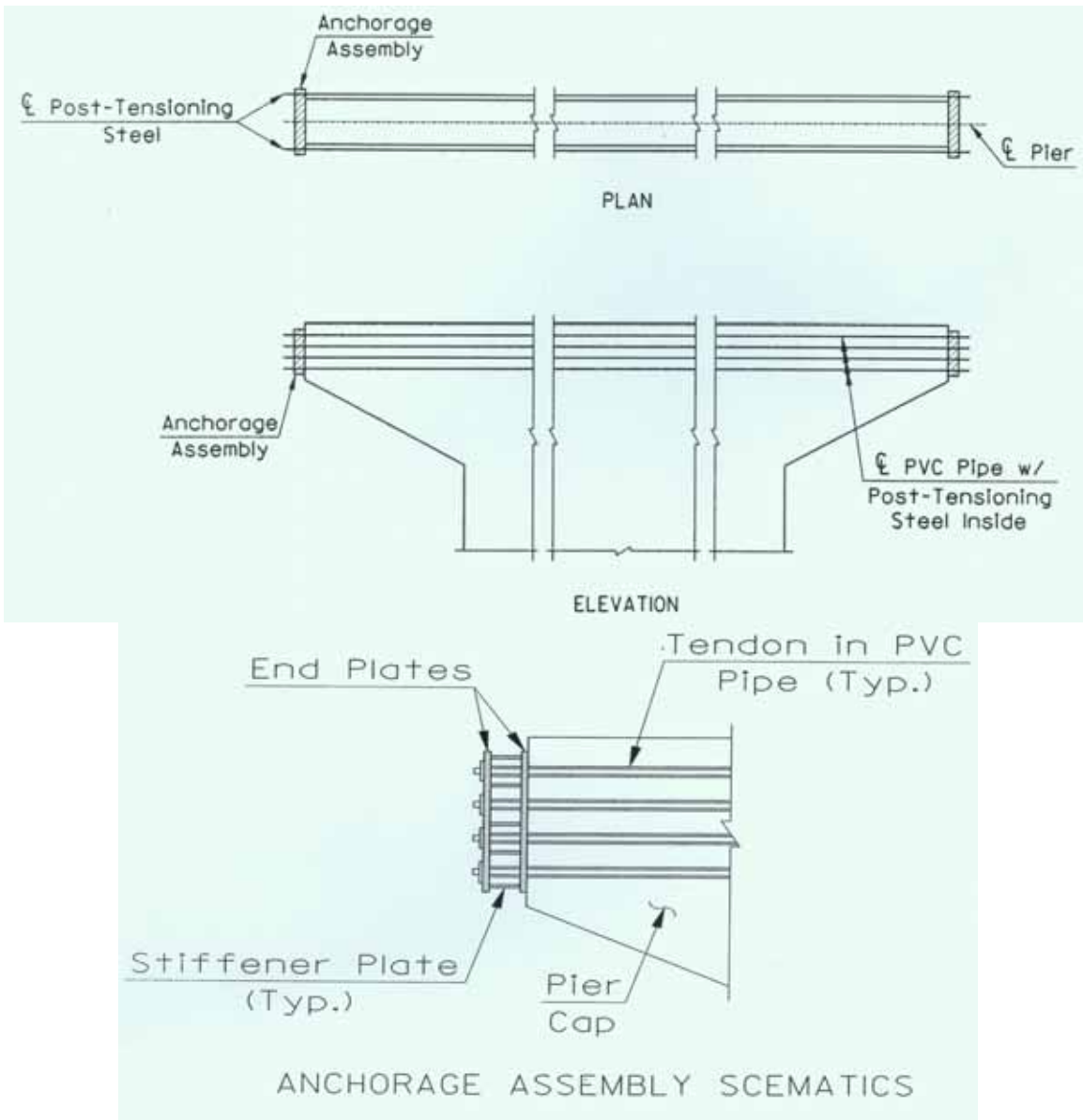
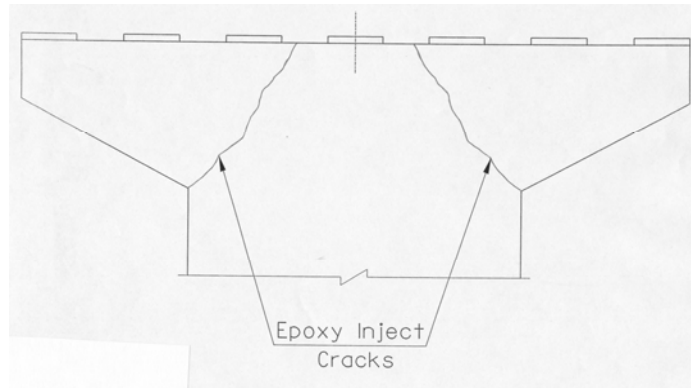

**Exhibit XII.8 Post-Tensioning Cracked Pier Cap**

## **STRENGTHENING COLUMNS WITH FIBER COMPOSITES**

Fiber reinforced polymers (FRP) fabrics are used to increase the axial and shear capacity of concrete columns and also to protect columns against intrusion of corrosive and deleterious materials. In seismic areas, these fabrics are primarily used to strengthen columns against earthquake loads. For column wrapping, FRP with carbon fibers are usually preferred to FRP with glass fibers. Although slightly more expensive, FRP with carbon fibers offer higher tensile strength, 2,400 MPa (350 ksi) versus 1,520 MPa (220 ksi).

### **CONSTRUCTION PROCEDURE**

The general procedure for column wrapping includes the following steps; manufacture's guidelines shall be followed for any specific application.

1. Surface preparation and column wrap should include the full exposed column height plus 0.6-m (2 ft) below ground.
2. All concrete surfaces should be repaired (including spalls and delaminations) and epoxy injection crack sealing performed. Surface should be free of sharp edges that can damage the fabric. Surface voids and depressions should be filled with epoxy.
3. Surface should be completely dry at the time of application of fabric. Newly repaired or patched surface should be cured at least 7 days prior to wrapping.
4. One prime coat of manufacture's epoxy should be applied to the surface and should be allowed to become tacky to touch.
5. Fabric (usually about 0.6 to 0.9 m (2 to 3 ft) wide) should be saturated at the job site with resin (usually epoxy) as per the specified fiber-resin ratio.
6. Saturated fabric should be wrapped around the column by hand lay-up, using methods that produce a uniform, constant tensile force that is distributed across the entire width of fabric.
7. Entrapped air, if any, should be rolled out before the resin sets.
8. Subsequent layer(s) should be applied continuously (or spliced) until specified number of layers is achieved at a section. Adjacent sections should utilize a butt joint.
9. The system should be protected against water and rainfall for at least 4 days following installation.
10. After the system is cured, a protective/aesthetic topcoat is applied to the fiberwrap surface.

### **PROTECTION AGAINST ONGOING REINFORCING STEEL CORROSION**

It is important that prior to wrapping a column, the condition of the concrete is assessed for any evidence that sound concrete may be critically contaminated with chlorides. If chlorides are present in the sound concrete, there is potential for corrosion of the reinforcing steel and deterioration of column after it is wrapped, which may be difficult to inspect.

Thus, if tests show that concrete is critically contaminated with chlorides, one of the following measures may be taken:

- Do not wrap the column.

- Extract the chlorides from the column by electrochemical methods prior to wrapping the column. This procedure requires a specialized contractor and can take up to 2 months.
- Admix a corrosion inhibitor in the repair/patch concrete. Subsequent to repair, apply a an effective spray-on type corrosion inhibitor on all unrepaired surfaces. Let the surface completely dry before wrapping the column. This procedure is only recommended when the concrete is not heavily contaminated with chlorides. An engineer should assess the condition of the concrete and approve wrapping the column. The corrosion inhibitor manufacture's recommendations should be closely followed.

## **SPREAD FOOTING REPAIR**

Deterioration of the spread footing concrete can result in breaking off the footing projections or spalling the sides. Severe deterioration may be caused by ice and debris pounding against the upstream side of the footing, water penetration resulting in corrosion of the reinforcing steel, or poor material in the footing. The area of the footing must not be reduced, as the load of the bridge must be distributed uniformly upon the material under the footing.

### **REPAIR PROCEDURE**

The repair of the footing proceeds as follows:

1. Water must be kept clear of work area by means of diversion channels, cofferdams, sandbags, or sheet piling if required.
2. Move the traffic to the opposite side of the bridge.
3. Chip away the deteriorated concrete until sound concrete is reached. Clean away all loose concrete with airblast or other means.
4. Install reinforcing bar, anchors and rods if they are to be used.
5. Construct forms that are adequate to restore the footing dimensions to the original size. It is common to extend the footing to cover a larger area and extend the sides downward if undermining has occurred.
6. Apply any patented polymer compounds or a neat cement paste for bonding just prior to pouring the new concrete into the forms.
7. Mix and pour the new concrete using a strong mix with low slump. Vibrate the concrete thoroughly to ensure a dense pour and a good bond.
8. When the new concrete has been cured for at least three days, remove the forms and any cofferdam and restore the stream channel to its proper course. Where shotcrete is to be used extensively on other parts of the structure, the repairs may be made using shotcrete.

## **CRACK IN SUBSTRUCTURE**

A footing may crack transversely due to uneven settlement of the pier or abutment. This will often be accompanied by a crack continuing up through the pier or abutment. It is advisable to seal the crack to prevent further intrusion of silt, debris, and water, which will attack the reinforcing steel. If the crack is moving it should be filled with a flexible material; otherwise, it will crack again. If the crack is not moving it can be bonded back together.

The most effective method of repairing substructure vertical cracks is epoxy injection, described in Chapter VII. In order to get maximum penetration of the epoxy filler, the first injection is made at the bottom of the crack. Starting at the bottom and moving up in gradual increments toward the top increases the pressure needed to apply the epoxy and should result in greater crack-filling penetration.

## **REPAIR PROCEDURE**

Another repair method that prevents moisture from entering a vertical crack is to rout and fill with non-sagging grout. The procedure is as follows:

1. Cut a groove at the surface along the crack approximately 25 to 50 mm (1 to 2 inches) in width and about 25 mm (1 in.) in depth using a small pneumatic chisel.
2. Thoroughly blowout and flush the crack and groove using high-pressure air and water.
3. Fill the groove with a stiff, non-sagging grout mixture.
4. Smoothen the surface with a spatula.
5. Apply a coating (such as urethane) in a band over the groove.

## **SURFACE DETERIORATION OF ABUTMENTS AND PIERS**

The first step in the repair of any type of deterioration in concrete is complete removal of all unsound concrete. No satisfactory repairs can be made until there is clean and sound concrete to which the new concrete can be bonded. Various types of air tools are most efficient for removing concrete. The edge of a cut out area should be undercut for deep patches to help retain the new material.

Surface deterioration in reinforcing concrete will frequently reach the first layer of reinforced steel and in this event, removal of the concrete should continue to a point 40 mm (1 1/2 inches) to 60 mm (2 1/2 inches) beyond that layer of steel. This provides an excellent anchor for the new concrete or shotcrete; if removal stopped at the plane of reinforcement, a cleavage plane is apt to develop at the interface between the old and the new concrete. Rust and other harmful materials should be removed from the reinforcing steel. Sandblasting should be used in those cracks where reinforcing steel is exposed because it cleans the concrete as well as the rust off the reinforcing steel.

Effective bonding of the new concrete to the old is usually accomplished with a bonding material and is particularly important when deep deterioration requires a large volume of concrete to be replaced. A grout of neat cement base can be used as an effective bonding agent. Grout can also be used when the form for the concrete is so inaccessible that an epoxy material cannot be applied effectively. The exposed area can be sloshed liberally with grout just prior to pouring the concrete.

## **SHOTCRETE**

Shotcrete may be used in filling the cavity after it is properly prepared. Shotcrete is a concrete or mortar pneumatically projected at high velocity onto a surface. Shotcrete repair is effective for

the repair of bridge beams, caps, piers, abutments, wing walls and decks. Since forms are not generally used for shotcrete, it is particularly effective on the underside of a deck for an overhead patch where there is no possibility of using a form. Shotcrete has the following characteristics:

Advantages:

- Superior bond,
- Greater strength due to high density,
- low shrinkage, and
- Requires no formwork.

Disadvantages:

- Space required for application
- Skill required for application
- Appearance
- High cost, particularly for small quantities

When the shotcrete method is used, no bonding agent is necessary. When the depth of the patch exceeds 75 mm (3 inches) (See Exhibit XII.9), hook anchors (shown as expansion bolts below) are secured to the existing concrete on 457-mm (18-inch) centers and 50-mm (2-inch) by 50-mm (2-inch) galvanized welded wire fabric is hooked and wired to the anchors. This anchoring system may be repeated for every 75 mm (3 inches) of depth of the shotcrete applied.

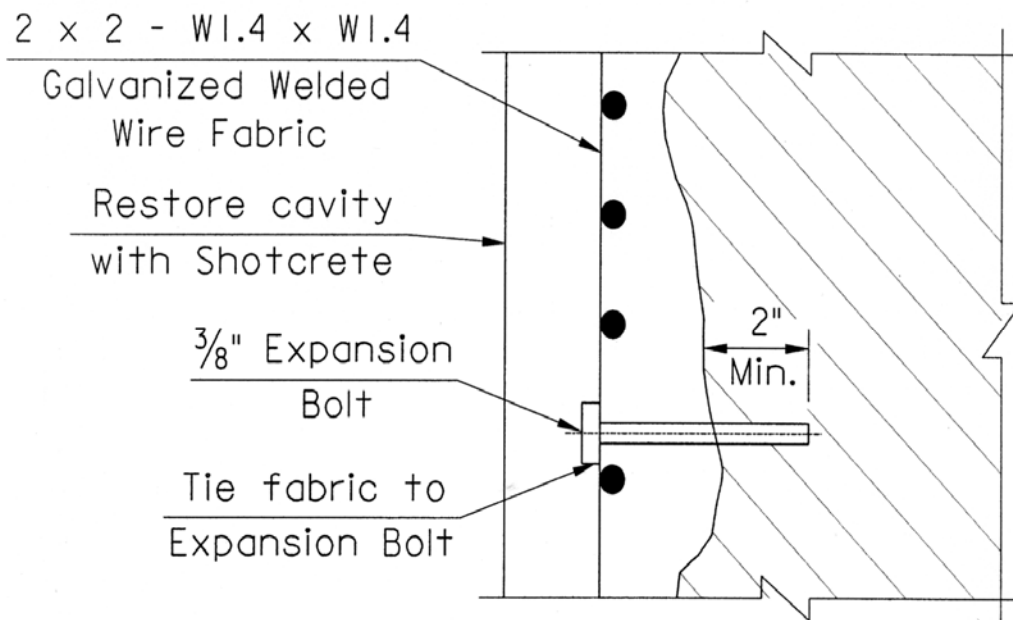

**Exhibit XII.9 Welded Wire Fabric Anchorage for Shotcrete**

It is recommended that whenever the repair is readily adaptable to the forming and pouring of concrete, that method should be used. Shotcrete tends to be wasteful of cement and requires much greater skill to obtain good results.



## **SHOTCRETE ISSUES**

### Shotcrete Considerations:

- Wet or Dry
- Surface Preparation
- Skilled Nozzleman
- Mix Design
- Alignment Control
- Finishing

### Shotcrete Mix Design:

- Prepackaged Mix
- Cement/Aggregate (1/3 – 1/5)
- Low Water-Cement Ratio
- Superplasticizers (Wet Mix)
- Air-Entrainment (9-12% Wet Mix)
- 7-15% Silica Fume
- Accelerators
- Fibers

### Shotcrete Surface Preparation:

- Remove Loose or Unsound Material
- Transition Changes in Thickness
- Abrasive (or Hydro) Blast Surface
- Avoid Feathered Edges
- Prewet Surface

### Shotcrete Application:

- Uniform Flow of Material
- Thin Bond coat First
- 90 Degree Nozzle Spray Angle
- Vary Angel Around Rebars
- Thick applications in Layers
- Remove Rebound Ahead
- Cure to Avoid Cracking

## **DETERIORATION AT THE WATERLINE**

Deterioration at the waterline is particular to abutments or piers in streams. It forms a depression or cavity in the concrete extending some distance above and below the average waterline of the stream. Deterioration at the waterline usually occurs on the upstream face or along the sides of the pier.

The repair problem is very similar to the surface deterioration problem except it is necessary to control the stream flow so that the work can be kept dry.

## **REPAIR PROCEDURE**

The following procedures can be used to repair deterioration of this type:

1. Dewater the abutment or pier.
2. Chip away all loose concrete in poor condition.
3. Clean the reinforcing bars of scale and loose rust.
4. Clean the surface in all areas where new concrete will be placed.
5. Chip or roughen the surface to provide a better bond between old and new concrete.
6. Construct a form of adequate strength
7. Apply a bonding agent to the surface (if possible) and fill the form with concrete.

This procedure can be quite expensive. It is advisable to check with an engineer before starting this repair. This is often an appropriate repair to be performed by contract.

---

## **C. PILE AND PILE BENT REPAIR**

---

### **INTRODUCTION**

Most piles require little maintenance because the material into which they are driven protects them and subsurface damage or deterioration is not common. Where piles are exposed, whether by design or by scour, there are potential problems. These problems include scaling and spalling of concrete piles, corrosion of metal piles or decay in timber piles and buckling in all types if the unsupported length becomes excessive.

### **PREVENTIVE MAINTENANCE**

Preventative maintenance of exposed piles is the same as other substructure elements of the same material. For example steel should be painted and concrete coated to protect against deterioration and corrosion. Timber piles are often used in bents to support small bridges. New cuts and boltholes in treated timber should be thoroughly coated with preservative materials to prevent moisture from entering the wood and causing decay.

It is essential that the area around timber pile bents and abutments is scalped and all weeds and brush removed from the vicinity because of the fire hazard. Where timber pilings are subject to frequent damage from ice, using discarded motor grader blades or other forms of armor should protect them. Scour of the streambed may expose piling below the flow line to a degree where additional cross bracing may be necessary to maintain stability.

### **JACKETS FOR PILE PROTECTION AND REPAIR**

Jackets are the most common type of pile protection or repair. They are used for protection of all types of piles: concrete, steel, and timber. The jacket can be for protection from abrasion damage, repair of section loss, or both. If the jacket were for protection only, it would consist of a liner placed around the area to be protected with a cementitious grout or epoxy resin pumped into the annular opening between the existing concrete and the liner. If the jacket is intended to repair structural damage the liner will provide space for reinforcement and the space between the liner and old pile is filled with concrete. The liner (form) is often a premolded fiberglass; however, it could be steel or fabric. Old drainpipes have been used as jacket liners.

### **JACKETS FOR CONCRETE PILES**

Deteriorated reinforced concrete and prestressed concrete piles can be encased with a concrete jacket after all unsound concrete has been removed and the surface prepared as described previously. Encasement will compensate for the cross-sectional loss and strengthen the pile. Reinforcing steel cages or reinforcing wire are placed around the pile before forms are placed. The reinforcement is usually epoxy-coated for protection against corrosion. Stand-offs are placed on the reinforcement before they are drawn tight to the pile. Forms, either rigid or flexible, are then installed and sealed. Concrete is placed in the form either by tremie or dewatering the form. After placing the concrete, the forms are either left in place permanently for further protection of

the pile or removed when the concrete is cured. Exhibit XII.10 shows a standard concrete pile jacket with steel reinforcing cage.

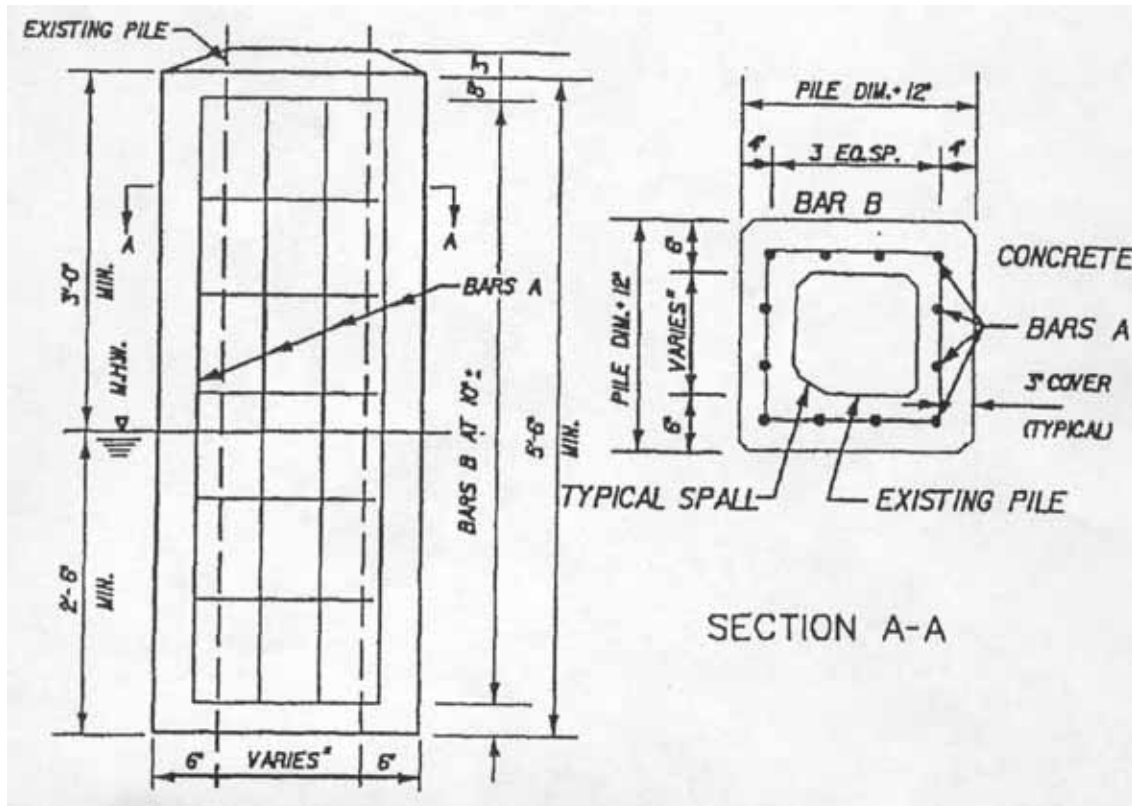

**Exhibit XII.10 Concrete Pile Jacket with Steel Reinforcing Cage**

Fiberglass forms are used by NCDOT to construct pile jackets in Exhibit XII .11. The damage normally extends above and below the waterline. Deteriorated concrete is removed using high-pressure water jets. The jacket extends approximately 600 mm (2 feet) beyond the damaged area at each end of the pile to account for any concrete segregation near the bottom or loose materials at the tops of the new concrete. Welded wire fabric or a reinforcement cage is wrapped around the repair area.

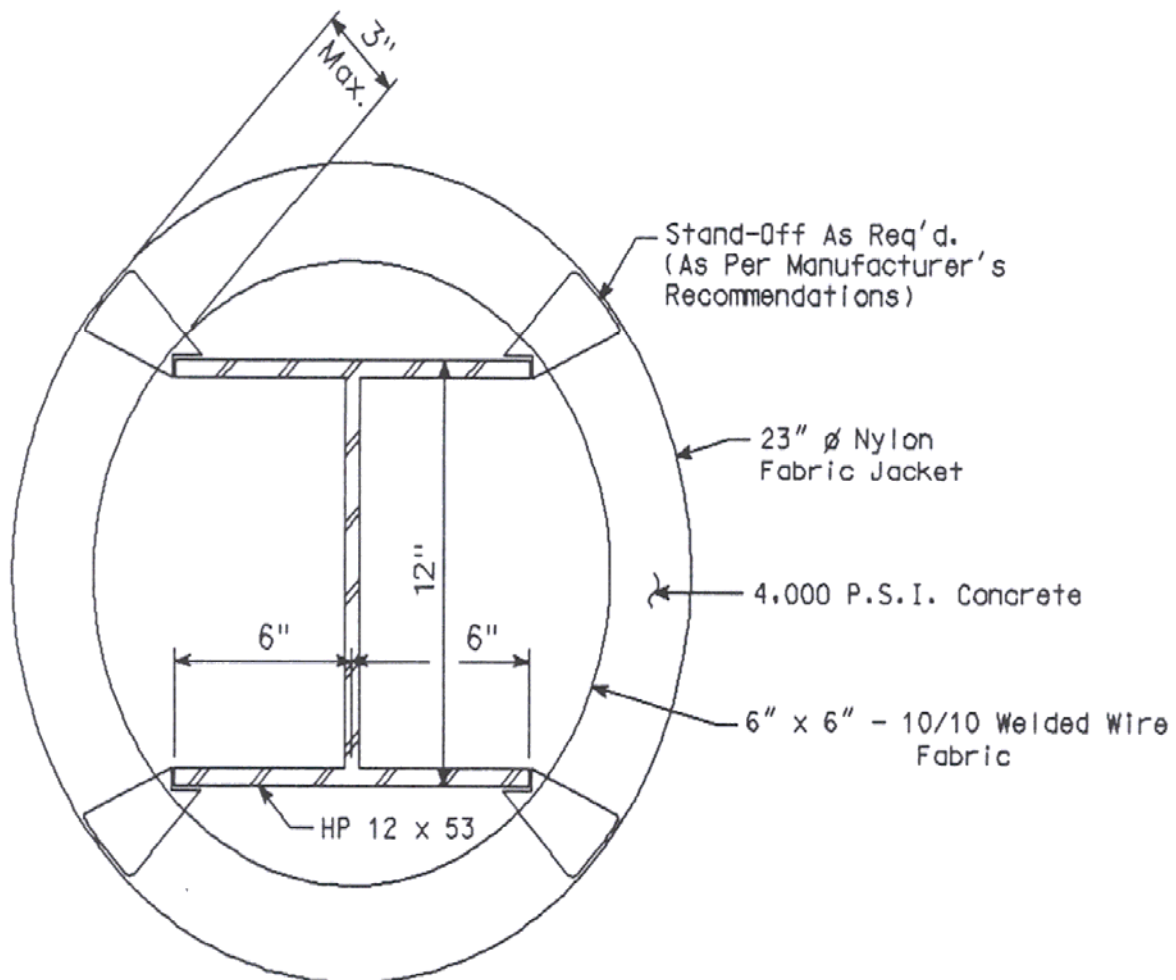

**Exhibit XII.11 Installing Pile Jacket**

The form has a vertical seam, so that it can be fitted around the pile. Subsequently, top and bottom centering devices and a bottom seal are placed. The form is secured in place with bolted bands and tightened to ensure full enclosure. If the length of the repair exceeds the length of the form, the piles may be repaired in two lifts. If the damage extends below the mudline, trenches are dug at the bottom to extend the repair into the mud zone.

## JACKETS FOR STEEL PILES

Pile jacketing of steel piles is basically the same as that described previously for concrete piles. Both flexible and rigid forms can be used. Often fiberglass and plastic forms are used because of ease of erection for underwater applications. Prior to pile jacketing, marine growth and corrosion are cleaned. Next, stands-offs are placed on the pile flanges before the forms are installed and concrete is placed. Exhibit XII.12 shows stand-offs inside a flexible form. Welded wire fabric is typically used to reinforce the concrete against cracking. Concrete jackets can cause accelerated corrosion on a steel pile when both concrete and water are in contact with the steel. A corrosion cell will develop either below the bottom of jacket or above the top of jacket. Concrete jackets should be extended well into the mudline and, well above the high waterline. The steel pile may be cathodically protected.

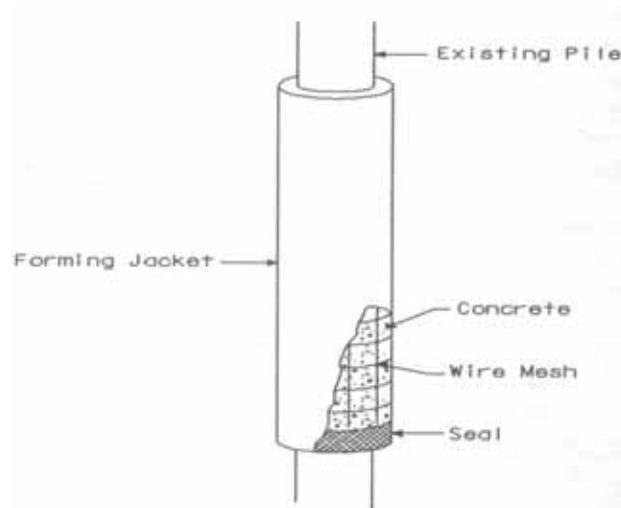

**Exhibit XII.12 Flexible Formed Pile Jacket**

## SPECIAL REQUIREMENTS FOR CONCRETE JACKETS

Special requirements for the installation of concrete-filled pile jackets shown in Exhibit XII .13 are as follows:

- Qualified divers for underwater survey and repairs
- Concrete pump for underwater placement



**Exhibit XII.13 Jacket Installation**

### Jacket Installation

The following steps will be required:

1. Scrape surface of the pile clean, removing deteriorated concrete or wood.
2. Sandblasting may be used to clean the exposed reinforcement in concrete piles above the waterline. Splice with new reinforcement if required. Install steel mesh reinforcing cage around timber pile or concrete pile. Use spacers to keep the forming in proper position.
3. Place the forming jacket around pile and seal the bottom of form against pile surface.
4. Pump suitable concrete into form through opening at the top. Sulfate-resistant concrete should be used in salt-water locations.
5. Finish top portion of repaired area.

## CORROSION PROTECTION OF PILES

Both steel and concrete piles should be protected against corrosion. Steel piles must be protected by coatings that prevent the dissolved oxygen in the water from contacting the steel. Epoxy coating systems and polyvinyl chloride barriers have been used. The portion of a steel pile in the water and beyond the concrete jacket has especially potential for galvanic corrosion. Zinc anodes can be attached to H piles to abate corrosion of steel in salt water as shown in Exhibit XII.14. Small anodes are used when less than 2.5 m (8 feet) of pile is exposed. Large anodes are

used when greater than 2.5 m (8 feet) of the pile is exposed. It should be noted that anodes will be consumed in time and the life of the anodes will depend on its weight.

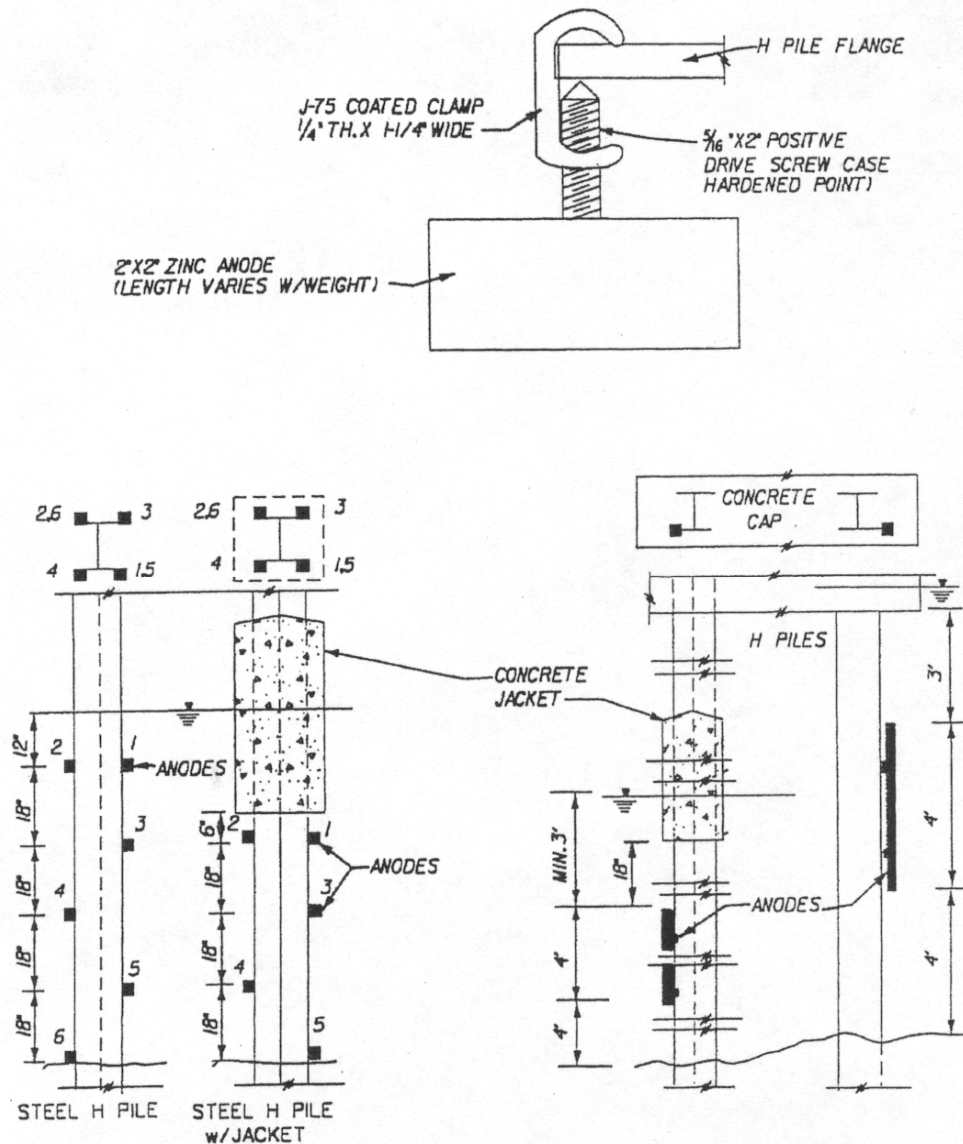

**Exhibit XII.14 Corrosion Protection of H Pile by Zinc Anodes**

Underwater, exposed reinforcing steel in concrete piles can be protected against corrosion by attaching zinc anodes to them as shown in Exhibit XII.15. If pile is repaired and jacketed, the reinforcing steel that is embedded in sound but chloride contaminated concrete has potential for corrosion. This corrosion and the subsequent concrete deterioration may be undetected because of the presence of the jacket. Attaching zinc anodes to the exposed reinforcing steel in the cavity prior to repair and jacketing can mitigate or stop the ongoing corrosion of the reinforcing steel in jacketed piles. Commercially available zinc anodes that are embedded in cementitious materials may be used for this purpose. Manufacturer's recommendations shall be followed.

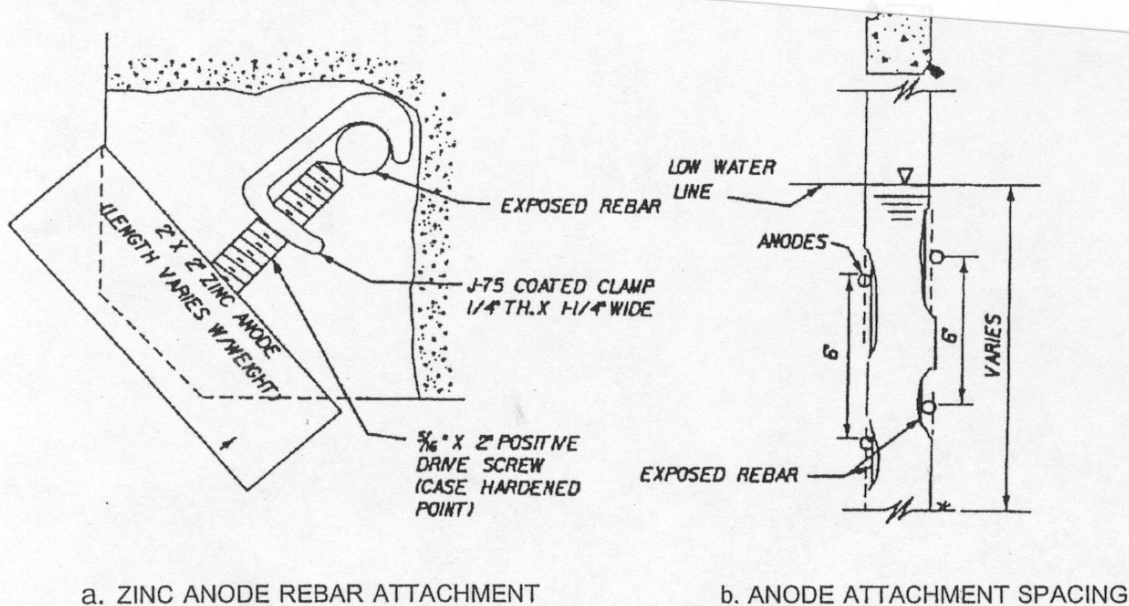

**Exhibit XII.15 Galvanic Cathodic Protection of Concrete Piles**

**ADDITION OF SUPPLEMENTAL PILES**

If the required equipment is available, or can be rented, it is often easier to add supplemental piles than repair the damaged piles. This is accomplished by cutting holes in the deck and driving steel H piles through the holes to build a new bent (See Exhibits XII.16 and XII.17). Since piles are driven from the deck, the deck must be capable of supporting the necessary pile driving equipment. Dry land or floating pile driving rig may be used, if possible.

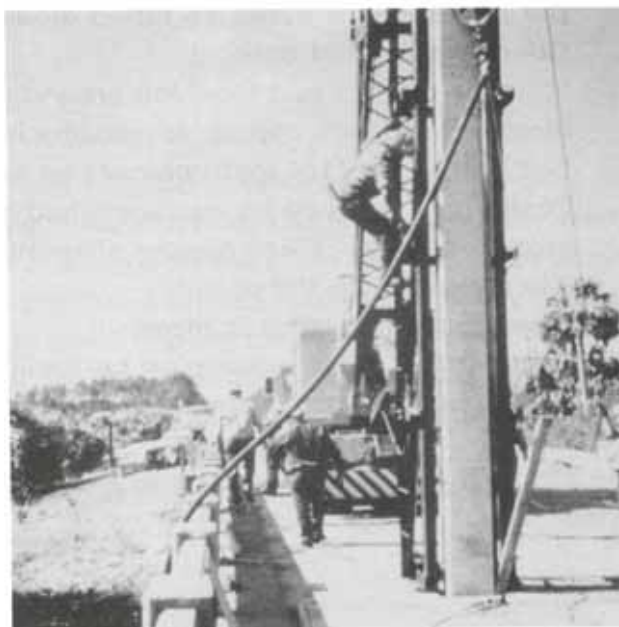

**Exhibit XII.16 Driving Piles through Deck**



## INSTALLATION PROCEDURE

The following sequential steps are involved in the addition of supplemental piles:

1. Restrict traffic to one lane or close the bridge to traffic as necessary to facilitate the repair.
2. Cut holes in the deck large enough to accommodate piles battered as necessary. The holes in the deck should be as close to the end diaphragm as possible to minimize the length of the subcap.
3. Drive piles and cut off at level sufficiently below pier cap to accommodate the subcap support beams.
4. Weld subcap support beams to the piles. Piles may be bent (or cut) to a slight degree to match the subcap.
5. Shim cap for fit to the existing pier cap.
6. Close deck holes and restore traffic.

The above-mentioned procedure requires pile driving and cutting equipment. Steel members should be designed, detailed and shop fabricated. Pavement breaking and concrete sawing may be required for use on concrete decks.

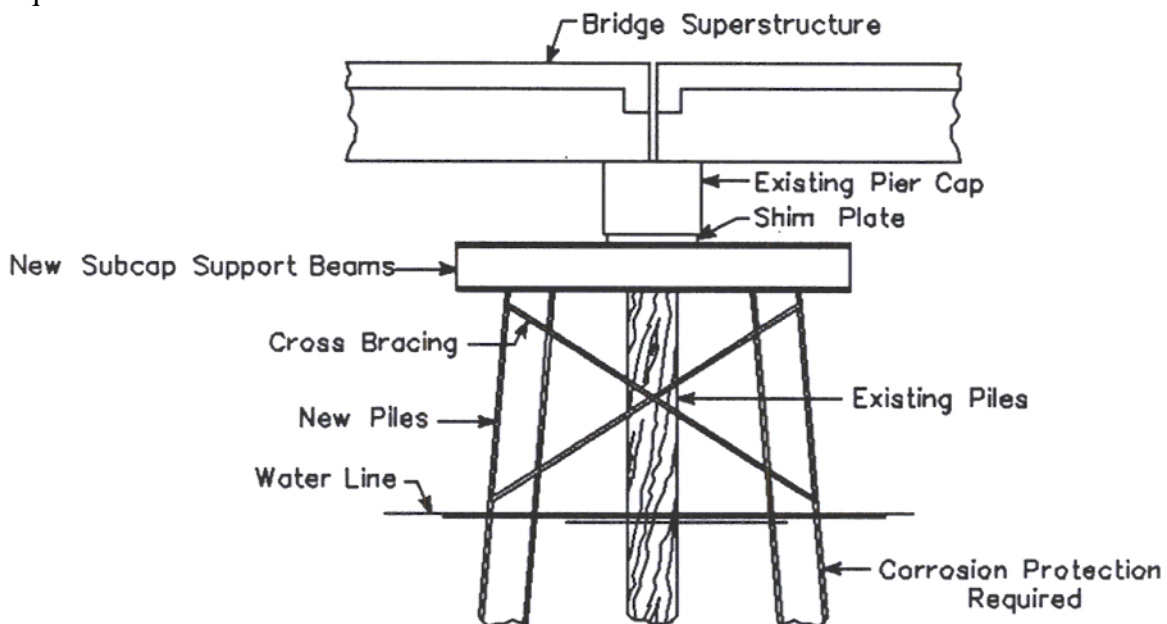

**Exhibit XII .17 Addition of Supplemental Piles**

## PILING REPAIRS

### STEEL PILES

Steel H-piles may be damaged particularly if located in waterways where they may be struck by heavy barges or near roadways as in work zones where they may be struck by heavy equipment. Damage in the form of bent, torn or cut flanges may effectively reduce the cross section and load-bearing capacity so that repair must be performed. More commonly, steel H-piles may



become severely corroded in a relatively short section near the main waterline in a waterway or as the result of unusual conditions such as broken drains. A steel pile that cannot be easily supplemented because of access or scheduling, may be strengthened by repairing with bolted channels as a temporary measure (See Exhibit XII.18).

### **Preliminary Planning**

Planning should include the following:

- Select appropriate channel size to meet strength and dimensional requirements.
- Determine length of damaged area and secure steel channels of selected size that have been fabricated in appropriate lengths with necessary hardware.

### **Equipment Required**

Equipment and tools necessary will include:

- Equipment for drilling bolt holes
- Protective coating material
- Necessary staging

### **Repair Procedure**

The following steps are entailed in the repair:

1. Clean damaged pile.
2. Locate extreme limits of deteriorated section.
3. Channel section should be 457 mm (18 inches) longer than the distance between these limits.
4. Thoroughly clean area to which channel is to be bolted.
5. Clamp channel section in place against pile.
6. Locate and drill holes through channel and pile for high strength bolts.
7. Place bolts and secure.
8. Remove clamps.
9. Coat with protective coating.

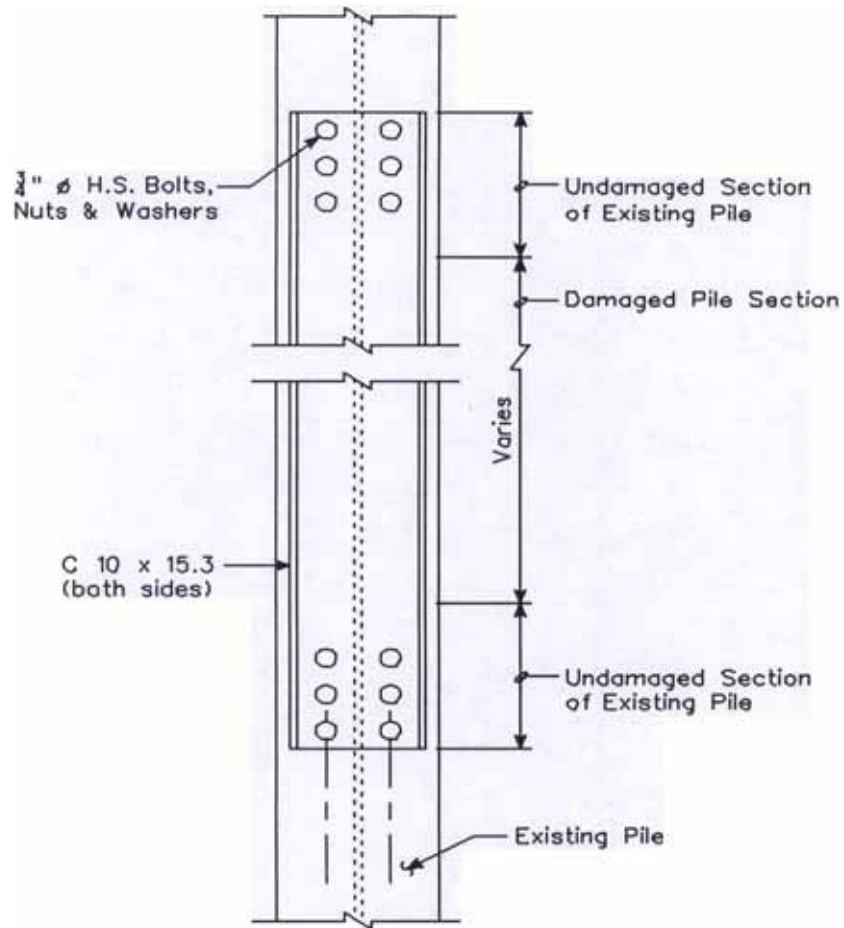

**Exhibit XII.18 Steel Pile Strengthening**

### **PATCH CONCRETE PILE**

Deteriorated concrete in a concrete pile should be removed until sound concrete is exposed. The reinforcing steel should then be cleaned of all rust and scale, and new concrete placed. Sufficient concrete should be removed so that new concrete is replaced to a minimum of 50 mm (2 inches) in depth. After forms are placed, all old concrete surfaces that adjoin new concrete should be covered with a bonding material. The new concrete is then placed or grout-injected, dry-packed aggregate may be used.

### **CASTING SUB-FOOTING TO CAP PILES**

Badly deteriorated piles that are exposed under a footing must be repaired before filling the void under the footing. Timber or steel piles may be spliced if accessible.

### **Repair Procedure**

Where there is insufficient room to repair by adding sections, one type of repair is:

1. The repair must be phased so that there is always sufficient support for the structure.
2. Cut out the deteriorated portion of the pile from the footing bottom to sound piling.
3. Form and pour new concrete from the footing bottom to the new top of the pile.
4. Maintain a hydrostatic head in the new concrete at the interface between the fresh concrete and the old footing when topping out the new concrete. Make every effort to eliminate voids at the interface. Pumping or pressure grouting may be required after the concrete cures.
5. Fill all the voids.

When the void that exposed the piles was caused by erosion, the work must be followed by some measure to prevent recurrence of the erosion.

## **SPLICING STEEL H PILE UNDER FOOTINGS**

Deteriorated steel can be repaired by adding sections when there is sufficient working space to weld or bolt them in place. Loss of section should be less than 50 percent. The web and flanges of the pile should be strengthened by welding steel plates extending far enough above and below the deteriorated area to carry the full load on the pile.

Where extreme section loss is present in the pile at the interface with the footing, repairs can be made by welding plates to form an angle with one leg against the footing and the other against the pile. Stiffeners should be placed across the angle as necessary. These angle plates should be placed on both flanges. When the welding is completed, all of the exposed piles should be given a heavy, protective coating. Fill should then be placed around the piles up to the bottom of the footing.

## **PILE SHELL REPAIR**

Filled shells are cast-in-place concrete piles. The metal shell is driven, the mandril withdrawn, and the shell filled with concrete. A problem that sometimes develops is corrosion of the shell with deterioration of the concrete.

Temporary support should be erected to assume the load when necessary. Rust and scale must be removed and the steel primed and painted. Where both the shell and the concrete are damaged, the deteriorated portion of the shell must be removed and a collar of sufficient strength and diameter placed around the pile. The collar is extended well above and below the affected area and a high quality, low shrinkage concrete or epoxy mortar or cementitious grout is pressure injected inside the collar to fill voids. The material should be well compacted so voids are completely eliminated.

## **REPAIRS TO INTERMEDIATE BENTS**

### **STEEL PILE BENTS**

Corrosion or deterioration in steel piling usually occurs at the water or ground line where wet and dry conditions alternate. Damage from impact may also be incurred where piles are near roadways or waterways.

Rust and corrosion should be removed by sandblasting or pneumatic needle scalers. Damaged areas should be straightened when possible and the deteriorated areas strengthened by welding steel plates extending far enough above and below the deteriorated area to restore the full load carrying capacity of the pile. Where deterioration is of a minor nature, plating by adding metal welds may be used. All repaired areas should be cleaned and painted as a good preventive maintenance practice.

## **ADD SECTION OF TIMBER PILE**

### **Repair Procedure**

When the portion below the ground is still sound, treated timber piles that have decayed or been damaged by fire or impact, can be repaired without the necessity of driving into the old pile.

1. After the required auxiliary support is in place, the old pile is cut off below the decayed or damaged area.
2. A new section of pile is cut about 150 mm (6 inches) shorter than the section removed. Plates are placed on top of the pile in place and on the bottom of the new section of piling.
3. A 19-mm (3/4-inch) bolt with a nut is welded to the bottom plate and extends through a hole in the top plate. By adjusting the nut on the bolt, the new section of pile can be raised until it is securely seated against the bent cap. Care must be taken to raise the new section of piling far enough to cause the bent cap to lift from the adjacent piling.
4. After the new section is in place, 6-mm (1/4-inch) thick angles are welded between the plates at each corner.
5. Used girder plates or flat stock are then bolted to the timber pile and extend down on the original pile about 300 mm (12 inches). The top of the pile is secured to the bent cap using straps.
6. A 1000 x 1000 x 600 mm (3 x 3 x 2 foot) block of dense concrete is poured around the pile. Any falsework may be removed after the concrete is poured.

## **SPLICE TIMBER PILES WITH STEEL COLUMNS**

Timber pilings that have decayed, been weakened by insects or marine organisms, or been structurally damaged by collision or overloading may be replaced by steel columns (See Exhibit XII.19).

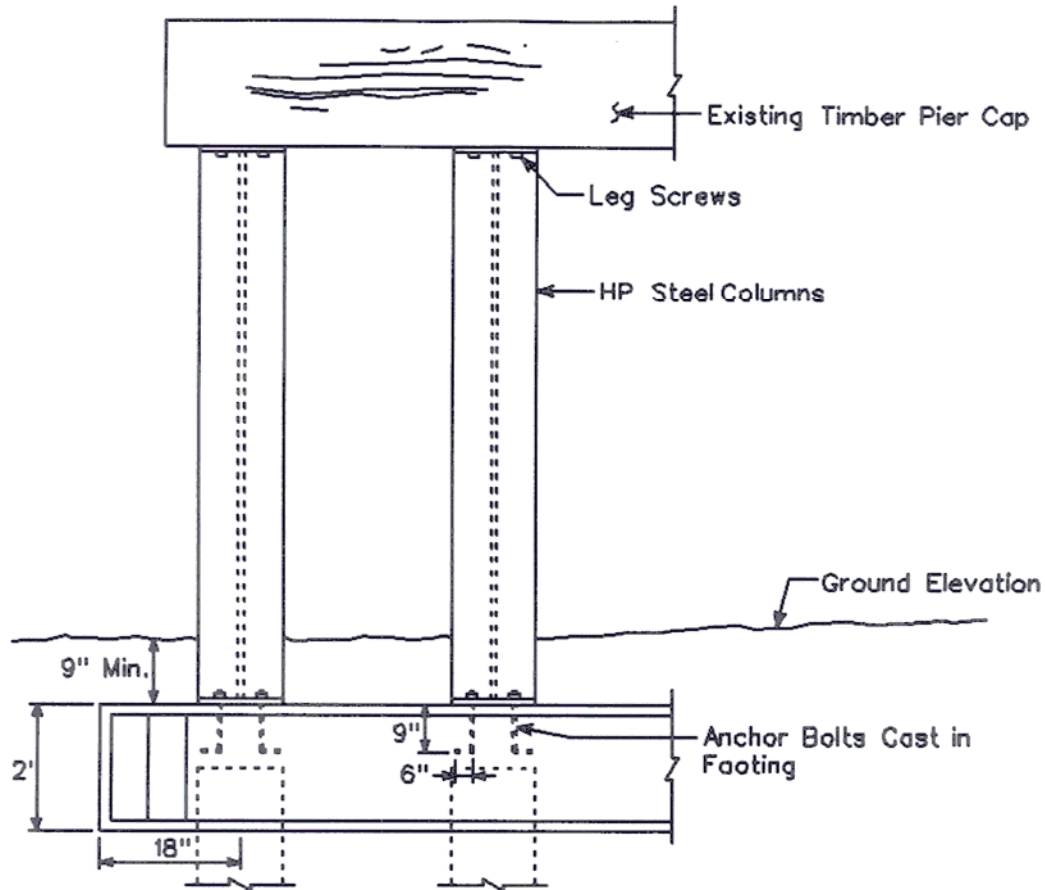

**Exhibit XII.19 Timber Piles Replaced with Steel Columns**

### **Preliminary Planning**

The following items should be considered as part of the planning process:

- Condition of existing piles below surface and existing cap
- Need for cofferdam to dewater work area
- Method of temporary support for superstructure during repairs
- Provisions to restrict traffic from work area during repairs

### **Equipment Required**

The equipment and tools needed are as follows:

- Wood cutting tools
- Light lifting equipment
- Welding and steel cutting equipment
- Wrenches and other small hand tools

## **Replacement Procedure**

The following steps will generally be required in the order given to accomplish the replacement:

1. Determine all cutoff points on the existing piles and the column length needed for the repair.
2. Construct temporary support for the superstructure before beginning the repair.
3. Construct cofferdam, if necessary, and dewater.
4. Excavate so that the top of the new footing will be a minimum of approximately 225 mm (9 inches) below the ground line.
5. Cut existing piles off so that they will project at least 300 mm (12 inches) into the new footing.
6. Separate the old sections of piling from the pier cap.
7. Form and pour concrete footings over the existing pile stubs.
8. Place the anchor bolts in the footing concrete prior to initial set.
9. Cut the steel columns to the proper length and weld on the base plates.
10. After concrete has reached required strength, attach new steel columns to footings with nuts and washers.
11. Attach the top of the new columns to the existing pier caps with lag screws.
12. Remove all temporary supports, backfill where necessary, and remove the cofferdam if one was used.

## **REPAIRS TO END BENTS**

Wingwalls and abutments that have the bottom of the backing exposed can be repaired temporarily by driving pieces of plank on end, vertically, along the bottom of the wing abutment. When a plank decays, the best method of repair is to replace the plank.

## **PILE SPLICE**

The timber splice method described previously is not to be used when replacing piling in the abutments, end bents, because it will not provide sufficient resistance to the overturning moment produced by the force of the fill against the back wall.

## **Repair Procedure**

To repair the top of an abutment pile:

1. Place falsework.
2. Cut the pile off below the decayed or damaged area.
3. A cylindrical steel pile shell, long enough to extend from the bottom of the cap down about 600 mm (2 feet) on the remaining pile, is split lengthwise and placed around the pile.
4. After the steel shell pile is pulled tight around the pile and welded, it is filled with concrete.
5. The falsework may be removed after the concrete has set.

Where it is not practical to repair the piling as described above, a new section of pile can be spliced to the old section using steel pipe or a band to hold the two butt ends together.

## **INSTALL HELPER BENT**

An existing substructure unit that is not capable of supporting the required load may be augmented with a timber helper bent. One example would be in the case of a concrete bridge pier in which the seat damage is so acute that the bearings are affected and the beams may dislodge. In this case, a timber helper bent adjacent to the pier would support the load and preclude bridge failure if bearing failure did occur. The timber helper may also be used to reduce the span length and increase bridge capacity in a situation when the beams are weakened or were not designed for current loads.

A structural engineer should determine the size and location of the helper bent whether the bridge can support a pile driving rig, or if the equipment can be located off the deck. A hydraulic engineer should determine if the additional restriction is acceptable. And provisions should be made to maintain traffic safely away from work area.

## **EQUIPMENT REQUIRED**

The following equipment may be needed:

- Pile driving equipment
- Deck cutting equipment
- Lifting equipment
- Scaffolding, if necessary

## **INSTALLATION PROCEDURE**

The following steps and considerations are involved in the installations of the helper bent shown in Exhibit XII.20:

1. Locate piles so that the deck beams will not interfere with driving.
2. Cut holes in only one lane of traffic at a time.
3. For timber deck, remove sufficient amount of timber decking to permit pile to go through hole. For reinforced concrete deck, remove sufficient amount of concrete in a square pattern to permit pile to go through hole. Cut reinforcing steel at center of hole and bend back out of way of pile.
4. Set piling and drive to required bearing.
5. Cut off piling approximately 6 mm (1/4 inch) above bottom of existing cap. If existing cap has settled, allowance must be made for grade differential.
6. Place cover plates over deck holes, open lane to traffic, and move to adjacent lane, repeating operation.
7. After all piles have been driven and cut off, jack up superstructure approximately 13 mm (1/2 inch) using existing pile bent.
8. Place timber cap over both rows of piling. For end bents, only one row of piles and cap is required.
9. Lower superstructure onto new caps and strap cap to piling. Shimming may be required to obtain bearing between superstructure and timber cap.

- 10. Remove deck plates and reconstruct deck. If deck is reinforced concrete, splice cut bars. Replace deck in one lane at a time. Concrete deck repair may be reopened to traffic if protected by steel plates.
- 11. Erect cross bracing on new pile bent. For intermediate bents, cross bracing between the two new bents is also required.

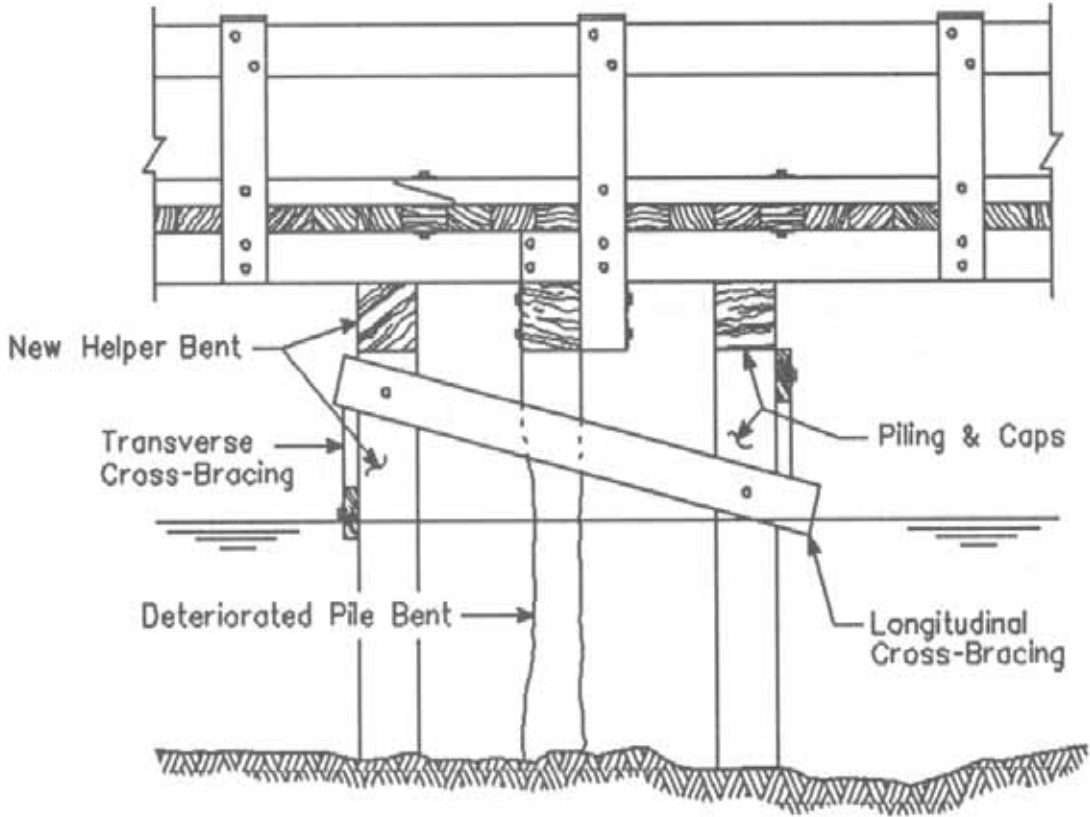

**Exhibit XII.20 Helper Bent**

**TIMBER CAP REPAIRS**

**CAPS ROTATING**

When timber pile abutments are pushed forward by the retained fill so that the pile cap is rotating, it indicates that the pile stays are broken or the abutment was constructed without stays. Abutments that are too high can also cause this problem.

**Repair Procedure**

This defect is corrected by the following procedure:

- 1. Remove all dirt from behind the abutment.



2. Pull the piles and caps back into position.
3. Repair or install pile stays.
4. Bury or drive deadmen behind the abutment and fasten and tighten cables, of the size specified by an engineer, to the piles with eyebolts (See Exhibit XII.24).

## TIMBER CAP REPLACEMENT

A common maintenance problem with pile caps is decay followed by longitudinal cracks and crushing caused by the load on the cap. The pile cap must be replaced when any of these problems arise. The superstructure is jacked either from the existing columns, as shown in Exhibit XII.21, or from a temporary bent. The decayed cap is removed and a new cap is secured in position.

To avoid future decay, timber pile caps that have deteriorated may be replaced by 300 mm (12 inch) steel beam caps. Stiffeners may be welded between the flanges directly over the piling. The steel cap is secured to the piling with a piece of 75 mm (3 inch) flat stock bent to encircle the top of the pile and welded to the bottom of the cap as shown in Exhibit XII.22.

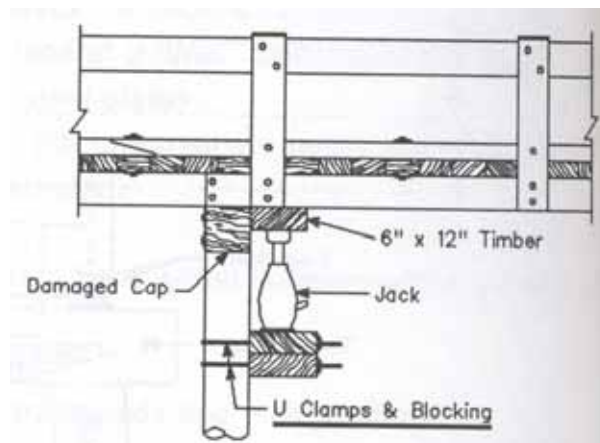

**Exhibit XII.21 Timber Cap Replacement**

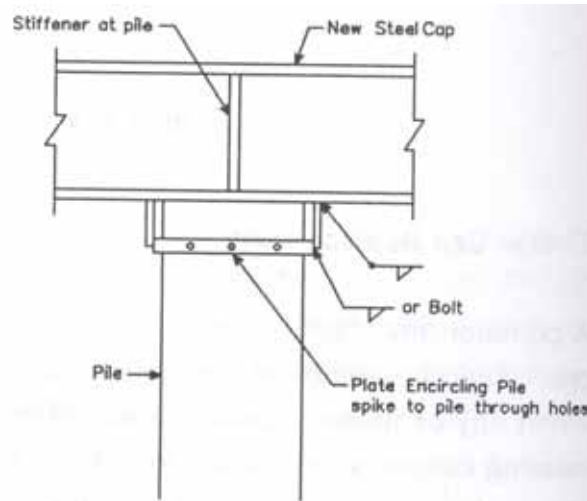

**Exhibit XII.22 Steel Replacement Cup**

## **TIMBER CAP STRENGTHENING**

The need to increase the load capacity of a bridge may arise due to improper sizes or defects in a particular member. An example is wood pier caps that have developed large lengthwise shrinkage cracks or many splits in the vicinity of bolt fasteners. A structural analysis may indicate such caps rate significantly lower than other members because of such defects. Provided the original cap is still in good structural condition and no decay is evident, strengthening the cap is often easier and cheaper than replacement. In some cases replacement may be very difficult due to access limitations or other factors and strengthening is the only logical alternative (See Exhibit XII.23).

### **Preliminary Procedures**

During the preliminary planning stage, necessary procedures should be determined. These procedures should then be scheduled in a logical order, and they may include the following:

- Ensure that the existing cap and columns are in good condition.
- Determine the required new section to satisfy needs. In this procedure, the new members will support live load only, since the original cap remains in place to carry the dead load.

### **Resources Required**

The resources which will be needed should be ascertained. They may include:

- Access to pile cap
- Light lifting equipment
- Wrenches
- Heavy duty drilling equipment
- Small hand tools

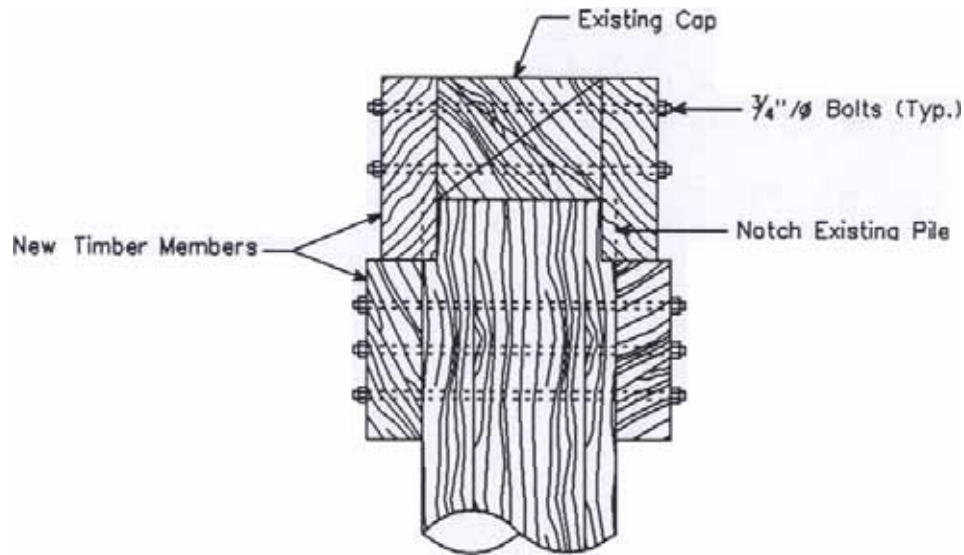

**Exhibit XII.23 Timber Cap Strengthening**

### **Construction Procedure**

The required construction procedures that should be carried out include:

1. Construct scaffolding, as required, around existing bent.
2. If pile diameter is wider than existing cap, notch existing piles or columns to accommodate new timber cap members.
3. Place new members snug against existing cap and stringers; temporarily clamp in place.
4. Drill 21-mm (13/16-inch) holes for 19-mm (3/4-inch) bolts.
5. Place bolts, tighten, and remove clamps.
6. Remove scaffolding.

### **INSTALLATION OF DEADMAN ANCHORAGE**

The force of earth and stone in the bridge approach, behind the bridge abutment, tends to push the abutment forward and may tend to rotate (tip over) the abutment. These forces may exceed the resistance of the abutment if the fill behind the abutment is unstable or the abutment is not adequately anchored. Deadmen are heavy masses (weights), usually concrete blocks, attached to the abutment with long steel rod and located in stable earth well behind the abutment to provide an anchor to prevent overturning of the abutment (See Exhibit XII.24).

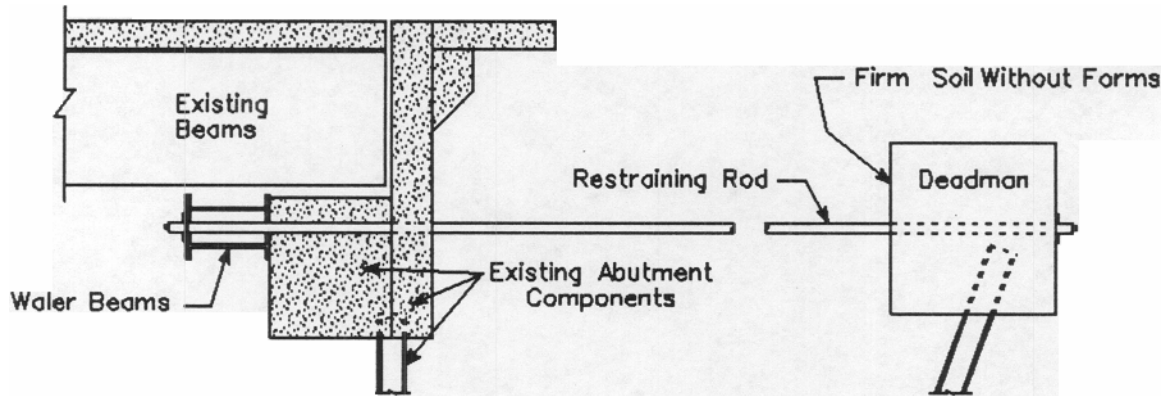

**Exhibit XII.24 Installation of Deadman**

## PRELIMINARY PLANNING

Planning includes:

- Calculations to determine the magnitude of the forces to be resisted by the deadman, and
- Determining the required size of deadman, size of restraining rod and whether piles are required.

## RESOURCES REQUIRED

The resources required will include:

- Excavation equipment
- Concrete
- Miscellaneous hand tools
- Light lifting equipment
- Drills

## CONSTRUCTION PROCEDURES

The construction procedures will include the following sequential steps:

1. Excavate the area where the deadmen are to be placed and provide a trench for the restraining rods.
2. Drive piles for the deadmen, if required.
3. Place formwork and concrete for the deadmen. Note that the side of the deadmen facing the abutment should be cast without forms. All forms may be eliminated if the condition of the excavation permits.
4. Drill through the backwall and place the restraining rods. Wrap and cast with tar or provide other means to protect rods from corrosion.
5. Bolt the restraining rods at the deadmen.
6. Place the waler beams and tighten the rods.

7. Grout holes in backwall. Back fill.

## **STABILIZATION OF SETTLED PIER**

Channel scour can cause undermining of footing resulting in differential settlement of pier. Corrective work includes the following:

### **PRELIMINARY PLANNING**

Preliminary planning includes:

- Thoroughly evaluate condition of foundation under pier footing.
- Establish new elevation with footings leveled and stabilized.
- Design new bearing pedestals to bring superstructure to proper grade.

### **RESOURCES REQUIRED**

Resource requirements are:

- Diving equipment
- Work boat
- Concrete drilling equipment
- Steel dowels
- Concrete pumping equipment
- High strength pretailored grout bags
- Reinforcing steel
- Prefabricated pedestals

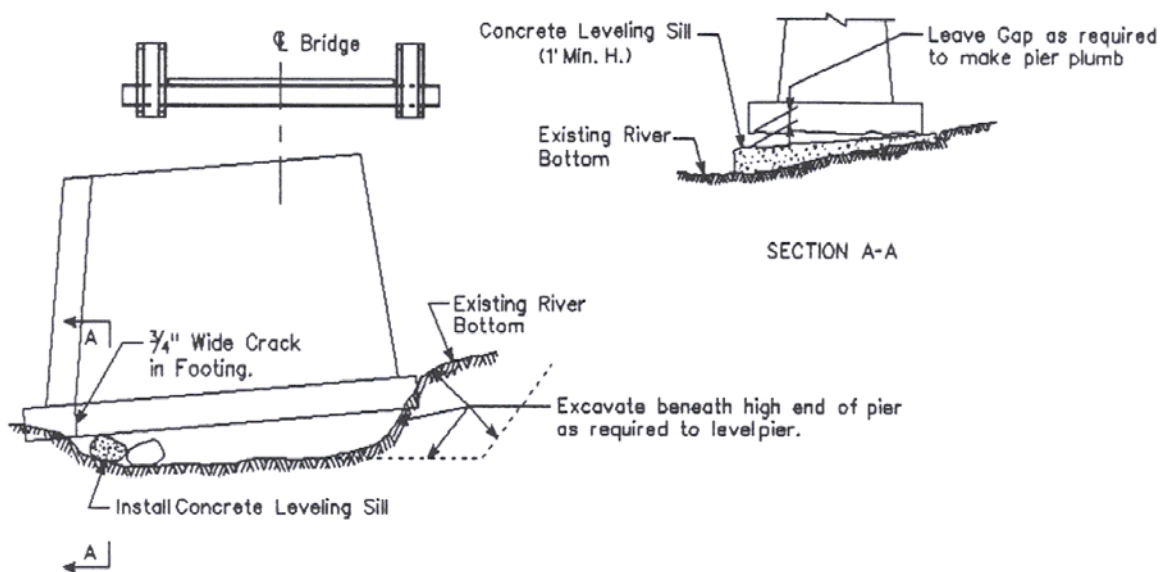

**Exhibit XII.25 Pier Settlement Stabilization**

## CONSTRUCTION PROCEDURE

The construction procedure is as follows:

1. Install concrete leveling sill to ensure pier stability during excavation. The sill consists of an appropriately positioned concrete grout bag extending the entire width of the pier.
2. Remove protruding boulders under footing.
3. Excavate to level footing using high-pressure water jets.
4. Install grout bags and fills with pressurized concrete to mold to and completely fill the cavity under pier.
5. Place grout bags around periphery of the pier to increase footing size and depth, thereby reducing further potential for undermining.
6. Install horizontal and vertical reinforcement through the grout bags.
7. Drill and grout dowels on 1-meter (3-ft) centers into existing stem and footing to anchor new work to old.
8. Install new bearings after jacking and blocking superstructure.

## TIMBER PILE REPAIR

Damaged or decayed timber piles may require replacement (See Exhibit XII .26).

### PRELIMINARY PLANNING

The preliminary planning includes:

- Determine extent of pile damage.
- Design and fabricate pile steel splice sleeve.
- Prepare to keep traffic off side of bridge being repaired.

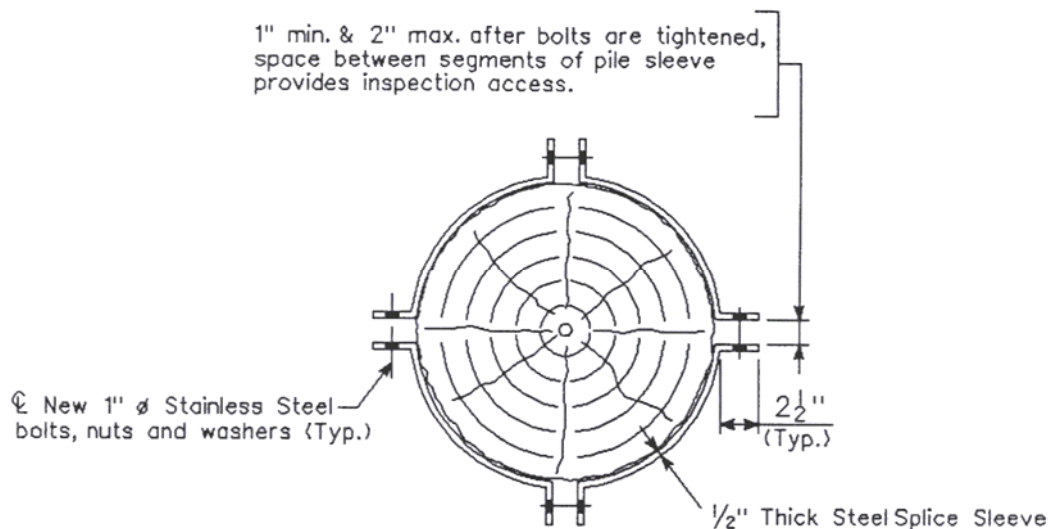

**Exhibit XII.26 Timber Pile Repair**

## RESOURCE REQUIREMENTS

The resource requirements include:

- Timber cutting and drilling equipment
- Light lifting equipment
- Staging

## CONSTRUCTION PROCEDURE

The construction procedure is as follows:

1. Move traffic from side of bridge being repaired.
2. Remove cross bracing as necessary to install new pile.
3. Install C12x30 to support cap.
4. Remove deteriorated portion of existing pile, cutting end off level.
5. Install new treated timber pile and pile-splice sleeve.
6. Re-install cross bracing.
7. Restore traffic.

---

## D. UNDERWATER REPAIR OF SUBSTRUCTURES

---

### INTRODUCTION

In 1981, only fifteen state transportation agencies routinely inspected bridge substructures below the waterline. Since that time nationwide attention has been focused on the inspection and maintenance of underwater bridge elements because of several collapses and near collapses related to failure of underwater bridge elements, the most publicized being the April, 1987 Schoharie Creek failure. In October 1988, revisions to the National Bridge Inspection Standards (NBIS) became effective. These revisions stipulate that all public highway bridges requiring underwater inspection be identified; that an appropriate inspection procedure be defined; and that the frequency of inspection, not to exceed five years, be determined. With the increased attention to underwater inspection, bridge owners are faced with solving the problems and potential problems now identified.

In the past, bridge maintenance supervisors have tended to think in terms of dewatering when underwater repairs were necessary. Cofferdams were installed and the damaged area dewatered so that workers could perform the repair work using the same methods as above water. Dewatering permits the use of conventional above-water solutions with confidence that they can be constructed and that the quality can be controlled. Dewatering is not always feasible.

## **ENGINEERING THE REPAIR**

It is important that solutions to the underwater problems are based on sound engineering. There is a tendency to make the solution fit one of a few common underwater repair techniques that are marketed because they lend themselves to underwater application.

A major concern is that the repair may only hide a structural problem while it continues to worsen. In some circumstances, hiding a problem is worse than doing nothing. For example, when contaminated concrete and corroded reinforcing steel are left in place to interface with new concrete, the corrosion process accelerates. Consequently, covering a reinforced concrete member with a stay-in-place form or jacket will not stop or prevent corrosion of the reinforcement. The member may look satisfactory while it is deteriorating to an unsafe condition.

The repair should address the deterioration process in the environment of the structure. If structural members are involved, the repair should be designed to provide the appropriate safety factor and redundancy. Unless special monitoring can be guaranteed, the repair should provide dependable service with the normal inspection and maintenance that can be realistically expected from the responsible agency.

Since most bridge engineers are not divers, it is important that they understand the problems and limitations in performing an underwater repair. All repair schemes used above water are not cost effective when performed by divers in underwater conditions. The time and cost of labor is more of a consideration for underwater work. For example, it may be less expensive to accept that the deterioration will continue and modify the load path by designing the repair to support the total load or by designing a supplemental supporting system than to remove and replace the damage.

## **CONTROLS ON WORK IN WATERWAYS**

The restrictions and permits required by agencies such as the Environmental Protection Agency (EPA), the Corps of Engineers, and OSHA must also be considered when planning an underwater repair. A permit is required from the Corp of Engineers if the work will involve a navigable waterway. EPA restricts pollution into the water or air and OSHA regulates worker safety. These considerations may significantly influence the cost of repair alternatives. For example, it may result in less environmental problems to leave an old element in place and add supplemental support rather than the destructive removal of damaged material. It may also cause less environmental problems to prefabricate the new element before it is placed in the water.

## **PROTECTION OF UNDERWATER BRIDGE ELEMENTS**

Cementitious and epoxy coatings have been applied under water to protect a concrete surface against abrasion, cover cracks, and make small repairs. These products are normally applied by hand as a thick mortar. The cementitious products often include antiwashout admixtures (described later) and accelerators. Cementitious materials are mixed above water and delivered to divers in a plastic bag. Epoxy resins applied under water must perform satisfactorily and cure under wet and low surface temperature conditions.



Underwater cathodic protection (CP) has achieved favorable results in preventing and halting corrosion of reinforcing steel. CP can be provided for the reinforcement by a sacrificial anode. In a marine environment and underwater application, the sacrificial anode cathodic protection is often recommended because of the low resistivity environment. This system uses a metal (sacrificial) anode higher in the galvanic series than the reinforcing steel to be protected. Zinc is often used as a sacrificial anode; however, magnesium and aluminum may also be used.

## **PRESSURE INJECTION OF CRACKS UNDERWATER**

When cracks expose the reinforcing steel to moisture, the stage is set for the corrosion process to begin. In salt water environments corrosion can occur very fast. With the proper selection of a water-compatible adhesive, normally an epoxy resin, dormant (non-moving) cracks saturated with water can be repaired. The procedure can also repair other small voids such as delaminations or honeycombed areas near the surface of the concrete. Pressure injection can be used, within limits, against a hydraulic head provided the injection pressure is adjusted upward to counteract the pressure of the hydraulic head. The material must displace the water as it is injected into the crack to ensure that the crack is properly sealed resulting in a watertight monolithic structural bond.

Epoxies must have certain characteristics to cure and bond the cracked concrete together. Many adverse elements are present inside the concrete crack such as water, contaminants carried by water, dissolved mineral salts, and debris from the rusting reinforcing steel. The typical low surface temperature of concrete underwater eliminates many products due to their inability to properly cure. The epoxy injection resins for cracks are formulated in low viscosity, and they do not shrink appreciably. The surface wettability of epoxy resin is of major importance, because the resin should displace all water in the crack and adhere to a wet surface and then cure in that environment.

The procedure involves cleaning of the crack by a high-pressure water jet system and shaping the surface of the concrete directly above the crack so that it can be sealed with a grout. Injection ports are installed in holes drilled to intersect the crack by a hydraulic or pneumatic drill. Subsequently, the surface of the crack is sealed with a grout material suitable for underwater use such as the cementitious or epoxy mortar described earlier. The purpose of the grout is to retain the adhesive as it is pumped into the crack. The adhesive is pressure-injected into the crack through the ports that are embedded in the grout at regular intervals. The injection sequence begins at the bottom and advances upward. The injection moves up when the adhesive reaches and begins to flow from that port. Epoxy resin is mixed either before or after pumping. Cracks varying in width from 0.005 cm (0.002 in) to 0.6 cm (0.25 in) may be injected successfully.

Epoxy pressure injection has gained widespread acceptance as a cost effective method to bond together and seal cracked structural concrete members. States reporting its use for underwater repairs include North Carolina, Virginia, and Louisiana.

The following precautions should be noted:

- Contaminants growing inside the crack, especially those found underwater can reduce the successful welding of cracks.
- Corrosion debris can also reduce the effectiveness of pressure injection.
- Time and patience is required for the successful injection project.
- Injection is labor-intensive. (As the temperature drops below 10°C (50°F), it becomes more difficult to pump the epoxies into fine cracks.)

Experience on the part of the diver in injection and the formulation of the epoxy for injection are very important.

## **CONCRETE REPAIR UNDERWATER**

### **CONCRETE REMOVAL**

Unless cathodic protection is used, the salt-contaminated concrete and rust must be removed from contact with existing reinforcing steel to ensure that the corrosion damage will not continue. However, concrete removal, especially under water, is labor intensive, difficult, and costly. Consequently, alternatives to concrete removal such as structural jackets or auxiliary members should be considered.

Concrete removal can be accomplished with high-pressure water jets or with chipping hammers. Construction joints between old and new concrete should be saw-cut prior to concrete removal to prevent featheredges. Hydraulic or pneumatic-powered concrete saws and chipping hammers may be adapted for underwater use. Mechanical grinders are also available for cleaning concrete surfaces. Surface preparation is required after concrete removal and prior to repair. High-pressure water jets, abrasive blasting, or mechanical scrubbers remove all loose and fractured concrete, marine organisms, and silt. In order to reduce the accumulation of new surface deposits where the water is heavily laden with contaminants, repairs should be made the day of final surface preparation.

### **FORMS**

There are forming materials and forming techniques developed specifically for underwater application. Forms are used to encase damaged concrete or masonry substructure units. Some pile jacketing forms are proprietary and marketed as a repair package. The shape, size, and location of the damaged element will often dictate the forming system used for the repairs. For underwater application, the cost of the forms is less a controlling factor than ease of erection and suitability. Commonly available polyethylene drainage pipe is also used as a form. In some repairs it may be economical and quicker to encase all piling with a jacketing wall (one concrete placement) rather than jacketing individual piles.

Fabric forms are relatively inexpensive and can be easily handled by a diver. While the appearance of the final repair is often irregular in thickness, shape and texture this is not a

problem when used underwater. Fabric forms are available with zippers for ease of installation, with spouts for pumping the repair material into the form, and with pressure seals to hold the material inside the form.

## **THE MIX**

Antiwashout admixtures are used to minimize washout of fines and cement from the concrete that is in contact with flowing water, prevent segregation of the concrete, reduce bleeding, decrease migration of moisture within the concrete mix, and inhibit water entrainment as the concrete is placed. These admixtures tend to make the concrete sticky. A water reducer or high range water reducer may be necessary with antiwashout admixtures to maintain slump. Slumps up to eight inches are possible. It is reported that concrete mixes containing antiwashout admixtures with either silica fume or fly ash can secure higher quality repairs at equal or lower cost than similar concretes made with high silica fume or high cement contents and no anti-washout admixtures.

## **UNDERWATER PLACEMENT**

While a limited amount of water is needed for hydration of the cement and workability of the concrete, additional water will damage the mix. As the ratio of water to cement is increased, permeability increases and strength decreases. If conventional concrete is dumped into water with no confinement as it falls through the water, it will lose fine particles, become segregated, or be completely disbursed, depending on the distance and current. Salt water mixed with the concrete will cause corrosion of the reinforcing steel. Special techniques are necessary to protect concrete as it is placed underwater.

## **BAGGED CONCRETE**

Concrete placed in bags can be used to repair deteriorated or damaged portions of concrete or masonry substructure elements underwater. Conventional bagged concrete repairs are made with small fabric bags prefilled with wet or sometimes dry concrete mix (often only sand and cement is used with the expectation that the moisture will move through the bag) and anchored together to form the exterior of the repair. The bags are small enough to be placed in position by hand. The interior portion of the repair is then filled with a tremie concrete or dewatered and filled with concrete. This method of repair is quick and can be performed by small crews with minimal skill and equipment. It is often used when the water is shallow enough not to require special underwater diving equipment.

Bagged concrete application was expanded when it became possible to take advantage of the durability and high strength of synthetic fibers to produce forms for casting concrete under water. These bags possess sufficient durability for use in marine environments exposed to cyclic changes and provide sufficient abrasion resistance. The properties of fabric-formed concrete are essentially the same as those expected of concrete cast in conventional rigid forms with one exception: the water-cement ratio of the concrete can be quite low at the surface since the permeable fabric allows bleed water to expel through these bags.

## **PREPACKED AGGREGATE CONCRETE**

In this method, after the area to be repaired is properly prepared and forms are in place, graded course aggregate is placed in the form. A cement-sand grout is then injected into the area containing the aggregate, displacing the water and filling the voids between the aggregate. This technique is particularly effective for underwater repairs where it would be difficult to place premixed concrete because of forming restrictions. Generally, an expansive grout with a fairly high water-cement ratio is used to provide fluidity. When antiwashout admixtures are added to the grout, forms do not have to be as watertight.

## **TREMIE CONCRETE**

Tremie concrete is placed under water through a gravity-filled pipe, which is called a tremie. The underwater portion of the pipe is kept full of plastic concrete at all times during the placement. Concrete placement starts at the lowest point and displaces the water as it fills the area. A mound of concrete is built up at the beginning of the placement. The bottom of the tremie must stay embedded in this mound throughout the placement to seal the tremie. The concrete is forced into the occupied area by gravity from the weight of the material in the tremie. The thickness of placement is limited to the depth of the mound of concrete.

Tremie concrete is best suited for larger volume repairs where there will not be a requirement to relocate the tremie frequently or for deep placements where it would not be practical to pump the concrete. Tremie concreting is simple with little equipment to malfunction. It is the most common method of placing concrete underwater.

## **PUMPED CONCRETE**

Pumped concrete is placed under water using the same equipment as above water. It is placed in a similar manner as tremie concrete except that the problem of getting the concrete into the tremie is eliminated. A direct transfer of concrete is provided, and the pump provides the force in moving the concrete. Unlike tremie, relocation is not a problem. As with the tremie, the placement must start at the bottom and the hose or pipe must stay submerged in the fresh concrete during placement but there is less need to lift the pipe. A handle on the end of the pipe will help the diver position the pipe.

## **FREE DUMP CONCRETE**

Within recent years, antiwashout concrete admixtures have been developed to minimize the loss of fines and reduce segregation when it is placed under water. This admixture makes the concrete mix more cohesive, yet sufficiently flowable for placement. It loses some of the self-leveling properties and tends to stick to equipment. Evidence of this method's success to date is somewhat limited. Therefore, it should be used with caution, when high quality concrete is not a primary consideration, and used only when there is minimal water current and drop distance, say 1 m (3 ft)

## **HAND-PLACED CONCRETE**

Hand-placed concrete is mortar or concrete that is placed by hand by the diver and packed or rammed for consolidation. This method is best suited for isolated repair sites. Use of accelerators, antiwashout admixtures, and a low water-cement ratio is recommended. The method is best suited for deep and narrow cavities. The concrete can be delivered to the diver by a bucket on a rope conveyor assembly or can be dropped to the diver in baseball-sized quantities through a pipe with holes cut in the sides to allow displaced water to escape, easing the descent of the concrete. Small quantities needed for patching can also be delivered to the diver in plastic bags.